

3. INVERTER MULTI-SPLIT SYSTEM ROOM AIR-CONDITIONER[4 room] (Air to air heat pump type)

**(OUTDOOR UNIT)
SCM80ZA**

(INDOOR UNIT)

SKM22ZA

SRRM40ZA

SKM25ZA

SKM28ZA

SKM32ZA

SKM40ZA

SKM50ZA



Большая библиотека технической документации

<https://splitsystema48.ru/instrukcii-po-ekspluatácii-kondicionerov.html>

каталоги, инструкции, сервисные мануалы, схемы.

CONTENTS

3.1	GENERAL INFORMATION	53
3.1.1	Specific features	53
3.1.2	How to read the model name	53
3.2	SELECTION DATA	54
3.2.1	Specifications	54
3.2.2	Range of usage & limitations	63
3.2.3	Exterior dimensions	64
3.2.4	Piping system	68
3.2.5	Selection chart	69
3.3	ELECTRICAL DATA	70
3.3.1	Electrical wiring	70
3.4	OUTLINE OF OPERATION CONTROL BY MICROCOMPUTER	73
3.5	APPLICATION DATA	86
3.5.1	Installation of indoor unit	87
3.5.2	Installation of remote controller	91
3.5.3	Installation of outdoor unit	92
3.5.4	Setup of volt select sw	93
3.5.5	Electrical wiring	93
3.5.6	Refrigerant piping	94
3.5.7	Test run and handling instruction	97
3.5.8	Installation of optional parts (Ceiling recessed type)	98
3.6	MAINTENANCE DATA	107
3.6.1	Trouble shooting	107
3.6.2	Servicing	115

3.1 GENERAL INFORMATION

3.1.1 Specific features

(1) **The long piping makes the location of the inside and units flexible.**

- No need for additional charge of refrigerant : 40 m
- Maximum piping length : 60 m

(2) **Connectable indoor capacity**

Number of connectable units : 3 to 4 units

Total of indoor units (class kW) : 12 kW

(3) **Indoor units are available with 6 capacities, in 2 types and 7 models.**

5 capacities 22, 25, 28, 32, 40, 50

2 types Wall mounted type (SKM), Ceiling recessed type (SRRM)

(4) **Inverter (Frequency converter) for multi-steps power control**

- Heating / Cooling

The rotational speed of a compressor is changed in step in relation to varying load, to interlock with the indoor and outdoor unit fans controlled to changes in frequency, thus controlling the power.

- Allowing quick heating/cooling operation during start-up period. Constant room temperature by fine-tuned control after the unit has stabilized.

(5) **Fuzzy control**

Fuzzy control calculates the amount of variation in the difference between the suction air temperature and the setting temperature in compliance with the fuzzy rules in order to control the air capacity and the inverter frequency.

(6) **Self diagnosis function**

We are constantly trying to do better service to our customers by installing such judges that show abnormality of operation as follows. (See Page 108)

3.1.2 How to read the model name

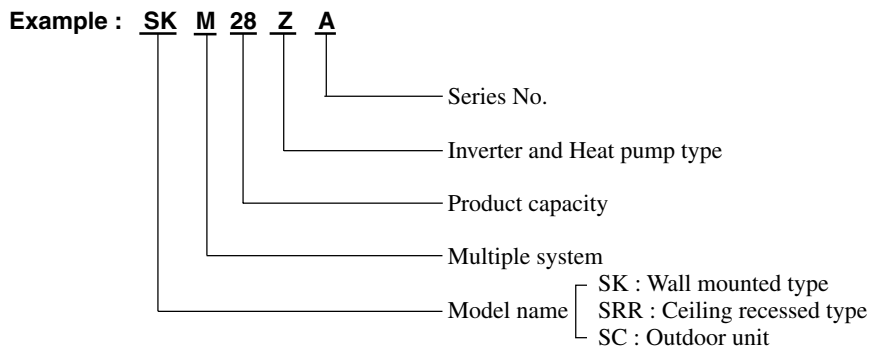

3.2 SELECTION DATA

3.2.1 Specifications

(1) Indoor unit

(a) Wall mounted type

Models SKM22ZA, 25ZA, 28ZA

Item		Models		SKM22ZA	SKM25ZA	SKM28ZA
		W				
Cooling capacity		W		2200	2500	2800
Heating capacity		W		3200	3400	4000
Noise level	Cooling	Sound level	dB	Hi : 38 Lo : 29		Hi : 39 Lo : 31
		Power level		Hi : 52 Lo : 43		Hi : 53 Lo : 45
	Heating	Sound level		Hi : 39 Lo : 30		Hi : 40 Lo : 32
		Power level		Hi : 53 Lo : 44		Hi : 54 Lo : 46
Exterior dimensions Height × Width × Depth		mm		250 × 750 × 178		275 × 790 × 174
Color				Ivory white		
Net weight		kg		7.5		
Air handling equipment Fan type & Q'ty				Tangential fan × 1		
Motor		W		17		18
Air flow (at high)	Cooling	CMM		7.0		7.7
	Heating			7.5		9.1
Air filter, Q'ty				Polypropylene net × 2 (Washable)		
Operation switch				Wireless-Remote controller		
Room temperature control				M.C thermostat		
Pilot lamp				RUN (Green), TIMER (Yellow)		
Safety equipment				Frost protection, Serial error protection Fan moter error protection		
Refrigerant piping	O.D	Liquid line	mm (in)	φ 6.35 (1/4")		
		Gas line		φ 9.52 (3/8")		
	Connecting method			Flare connecting		
	Attached length of piping			Liquid line : 0.4m Gas line : 0.35m		
	Insulation			Necessary (Both Liquid & Gas lines)		
Drain hose				Connectable		
Accessories (including)				Mounting kit		
Optional parts				—		
Outdoor units to be combined				SCM80ZA		

Notes (1) The data are measured at the following conditions.

Operation DB	Item	Indoor air temperature		Outdoor air temperature		Standards
		DB	WB	DB	WB	
Cooling		27°C	19°C	35°C	24°C	ISO-T1, JIS C9612
Heating		20°C	—	7°C	6°C	ISO-T1, JIS C9612

(2) Capacity indicated is the rated capacity with one unit operating under ISO-T1 standards conditions.

Models SKM32ZA, 40ZA, 50ZA

Item		Models		SKM32ZA	SKM40ZA	SKM50ZA
		W				
Cooling capacity		W		3200	4000	5000
Heating capacity		W		4500	5400	6700
Noise level	Cooling	Sound level	dB	Hi : 40 Lo : 30	Hi : 42 Lo : 31	Hi : 43 Lo : 31
		Power level		Hi : 54 Lo : 44	Hi : 56 Lo : 45	Hi : 57 Lo : 45
	Heating	Sound level		Hi : 41 Lo : 32	Hi : 42 Lo : 32	Hi : 43 Lo : 31
		Power level		Hi : 55 Lo : 46	Hi : 56 Lo : 46	Hi : 57 Lo : 45
Exterior dimensions Height × Width × Depth		mm		275 × 790 × 174		275 × 790 × 189
Color				Ivory white		
Net weight		kg		8.0		9.0
Air handling equipment Fan type & Q'ty				Tangential fan × 1		
Motor		W		18		26
Air flow (at high)	Cooling	CMM		9.0	9.5	10
	Heating			10	10	10.5
Air filter, Q'ty				Polypropylene net × 2 (Washable)		
Operation switch				Wireless-Remote controller		
Room temperature control				M.C thermostat		
Pilot lamp				RUN (Green), TIMER (Yellow)		RUN (Green), TIMER (Yellow), ECONO (Orange), HI POWER (Green)
Safety equipment				Frost protection, Serial error protection Fan moter error protection		
Refrigerant piping	O.D	Liquid line	mm (in)	φ 6.35 (1/4")		
		Gas line		φ 12.7 (1/2")		
	Connecting method			Flare connecting		
	Attached length of piping			Liquid line : 0.4m Gas line : 0.35m		
Insulation			Necessary (Both Liquid & Gas lines)			
Drain hose				Connectable		
Accessories (including)				Mounting kit		
Optional parts				—		
Outdoor units to be combined				SCM80ZA		

Notes (1) The data are measured at the following conditions.

Item	Indoor air temperature		Outdoor air temperature		Standards
	DB	WB	DB	WB	
Cooling	27°C	19°C	35°C	24°C	ISO-T1, JIS C9612
Heating	20°C	—	7°C	6°C	ISO-T1, JIS C9612

(2) Capacity indicated is the rated capacity with one unit operating under ISO-T1 standards conditions.

(b) Ceiling recessed type**Model SRRM40ZA**

Item		Model	SRRM40ZA
Cooling capacity		W	4000
Heating capacity		W	6000
Noise level	Cooling	Sound level	Hi : 41 Lo : 33
		Power level	Hi : 55 Lo : 47
	Heating	Sound level	Hi : 44 Lo : 34
		Power level	Hi : 58 Lo : 48
Exterior dimensions Height × Width × Depth		mm	230 × 740 × 455
Color			—
Net weight		kg	19
Air handling equipment Fan type & Q'ty			Multiblade centrifugal fan × 2
Motor		W	21
Air flow (at high)	Cooling	CMM	8.5
	Heating		9.5
Air filter, Q'ty			—
Operation switch			Wireless-Remote controller
Room temperature control			M.C thermostat
Pilot lamp			RUN (Green), TIMER (Yellow)
Safety equipment			Frost protection, Serial error protection Drain error protection
Refrigerant piping	O.D	Liquid line	φ 6.35 (1/4")
		Gas line	φ 12.7 (1/2")
	Connecting method		Flare connecting
	Attached length of piping		—
Insulation			Necessary (Both Liquid & Gas lines)
Drain hose			Connectable
Accessories (including)			Mounting kit
Optional parts			See Page 98
Outdoor units to be combined			SCM80ZA

Notes (1) The data are measured at the following conditions.

Operation DB	Item	Indoor air temperature		Outdoor air temperature		Standards
		DB	WB	DB	WB	
Cooling		27°C	19°C	35°C	24°C	ISO-T1, JIS C9612
Heating		20°C	—	7°C	6°C	ISO-T1, JIS C9612

(2) Capacity indicated is the rated capacity with one unit operating under ISO-T1 standards conditions.

(2) Outdoor unit

Model SCM80ZA

Item		Model	SCM80ZA
Cooling capacity		W	8000 (1800~8600)
Heating capacity		W	9500 (2000~10800)
Power source			1 Phase 220/230/240V 50Hz
Power consumption	Cooling	W	3270 (750~3700)
	Heating		3140 (750~3800)
Running current	Cooling	A	18.0/17.2/16.4
	Heating		17.2/16.6/16.1
Noise level	Sound level	dB	Cooling : 48/48/49 Heating : 49/50/50
	Power level		Cooling : 62/62/63 Heating : 63/64/64
Exterior dimensions Height × Width × Depth		mm	845 × 880 × 340
Color			Polar white
Net weight		kg	80
Refrigerant equipment Compressor type & Q'ty			HV461X3-S12MS × 1
Motor		kW	1.8
Starting method			Direct start
Refrigerant control			Capillary tubes + Electric expansion valve × Thermal expansion valve
Refrigerant		kg	R22 2.6 (Pre-charged up to the piping length of 40m)
Refrigerant oil		ℓ	1.4 (SUNISO 4GSD)
Air handling equipment Fan type & Q'ty			Propeller fan × 1
Motor		W	55
Air flow (at high)		CMM	56
Shock & vibration absorber			Rubber (for compressor)
Safety equipment			Compressor overheat protection, Overcurrent protection Power transistor overheat protection
Refrigerant piping	Size × Core × Number	mm (in)	Liquid line: φ 6.35 (1/4") × 4 Gas line: φ 9.52 (3/8") × 2 + φ 12.7 (1/2") × 2
	Connecting method		Flare connecting
	Attached length piping		—
	Insulation		Necessary (Both Liquid & Gas lines)
Power source supply			Terminal block (Screw fixing type)
Connection wiring	Size × Core number		1.5 mm ² × 4 cores (Including earth cable)
	Connecting method		Terminal block (Screw fixing type)
Accessories (included)			Union : (φ 9.52 → φ 12.7) × 2, (φ 12.7 → φ 9.52) × 2 Installation sheet, Manual instruction
Indoor units to be combined			SKM22, 25, 28, 32, 40, 50 type SRRM40 type

Notes (1) The data are measured at the following conditions.

Operation DB	Item	Indoor air temperature		Outdoor air temperature		Standards
		DB	WB	DB	WB	
Cooling		27°C	19°C	35°C	24°C	ISO-T1, JIS C9612
Heating		20°C	—	7°C	6°C	ISO-T1, JIS C9612

(2) The values for capacity and power consumption shown in a range () indicate the minimum and maximum of the range.

(3) If the piping length exceeds 40 m, additional charging is required. (20g/m)

(3) Operation data

- The combinations of the indoor units is indicated by numbers. They are read as follows.

(Example) SKM22ZA → 22 SKM50ZA → 50

- The capacity of the indoor units is shown by rooms. If this exceeds the maximum capacity of the outdoor unit, the demand capacity will be proportionally distributed.
- If units are to be combined, use the table below to make the proper selection.

(a) Heating

Indoor unit combination		Heating capacity (kW)							Power consumption (W)			Standard current (A)		
		Room heating capacity (kW)				Total capacity (kW)			Min.	Standard	Max.	220V	230V	240V
		A room	B room	C room	D room	Min.	Standard	Max.						
1 room	22	3.2				2.0	3.2	3.9	750	860	1110	4.7	4.5	4.4
	25	3.4				2.0	3.4	4.0	750	980	1220	5.4	5.2	5.0
	28	4.0				2.4	4.0	4.7	850	1120	1390	6.1	5.9	5.7
	32	4.5				2.4	4.5	5.6	850	1320	1740	7.2	7.0	6.8
	40	5.4				3.0	5.4	6.0	1050	1700	2020	9.3	9.0	8.7
	50	6.7				3.0	6.7	7.9	1050	2200	2780	12.0	11.6	11.3
2 room	22+22	2.9	2.9			3.5	5.8	6.7	1250	1900	2350	10.4	10.0	9.7
	22+25	2.9	3.3			3.5	6.2	7.3	1250	2050	2590	11.2	10.8	10.5
	22+28	2.9	3.8			3.5	6.7	7.9	1250	2200	2780	12.0	11.6	11.3
	22+32	2.9	4.1			3.5	7.0	8.3	1250	2400	3060	13.1	12.7	12.3
	22+40	2.8	5.2			3.5	8.0	9.2	1250	2780	3440	15.2	14.7	14.2
	22+50	2.7	6.2			3.5	8.9	10.1	1250	3220	3800	17.6	17.0	16.5
	25+25	3.35	3.35			3.5	6.7	7.9	1250	2200	2780	12.0	11.6	11.3
	25+28	3.3	3.6			3.5	6.9	8.2	1250	2340	2980	12.8	12.4	12.0
	25+32	3.2	4.2			3.5	7.4	8.7	1250	2540	3210	13.9	13.4	13.0
	25+40	3.2	5.1			3.5	8.3	9.6	1250	2920	3630	16.0	15.4	15.0
	25+50	3.0	5.9			3.5	8.9	10.2	1250	3220	3800	17.6	17.0	16.5
	28+28	3.6	3.6			3.5	7.2	8.5	1250	2500	3170	13.7	13.2	12.8
	28+32	3.6	4.1			3.5	7.7	9.0	1250	2580	3230	14.1	13.6	13.2
	28+40	3.5	5.1			3.5	8.6	9.9	1250	3070	3800	16.8	16.2	15.7
	28+50	3.2	5.7			3.5	8.9	10.2	1250	3210	3800	17.6	17.0	16.5
	32+32	4.1	4.1			3.5	8.2	9.5	1250	2880	3590	15.8	15.2	14.8
	32+40	4.0	4.9			3.5	8.9	10.1	1250	3220	3800	17.6	17.0	16.5
	32+50	3.5	5.5			3.5	9.0	10.3	1250	3210	3800	17.6	17.0	16.5
40+40	4.5	4.5			3.5	9.0	10.2	1250	3210	3800	17.6	17.0	16.5	
40+50	4.0	5.1			3.5	9.1	10.4	1250	3190	3800	17.5	16.9	16.3	
50+50	4.6	4.6			3.5	9.2	10.5	1250	3180	3800	17.4	16.8	16.3	
3 room	22+22+22	2.8	2.8	2.8		4.8	8.4	9.7	1750	2970	3690	16.3	15.7	15.2
	22+22+25	2.8	2.8	3.1		4.8	8.7	10.0	1750	3120	3800	17.1	16.5	16.0
	22+22+28	2.7	2.7	3.5		4.8	8.9	10.1	1750	3220	3800	17.6	17.0	16.5
	22+22+32	2.6	2.6	3.7		4.8	8.9	10.2	1750	3220	3800	17.6	17.0	16.5
	22+22+40	2.4	2.4	4.2		4.8	9.0	10.3	1750	3200	3800	17.5	16.9	16.4
	22+22+50	2.1	2.1	4.9		4.8	9.1	10.4	1750	3190	3800	17.5	16.9	16.3
	22+25+25	2.7	3.1	3.1		4.8	8.9	10.1	1750	3220	3800	17.6	17.0	16.5
	22+25+32	2.6	3.0	3.3		4.8	8.9	10.2	1750	3220	3800	17.6	17.0	16.5
	22+25+40	2.5	2.8	3.7		4.8	9.0	10.2	1750	3210	3800	17.6	17.0	16.5
	22+25+50	2.3	2.6	4.2		4.8	9.1	10.3	1750	3200	3800	17.5	16.9	16.4
	22+25+50	2.1	2.4	4.7		4.8	9.2	10.5	1750	3180	3800	17.4	16.8	16.3
	22+28+28	2.5	3.2	3.2		4.8	8.9	10.2	1750	3210	3800	17.6	17.0	16.5
	22+28+32	2.4	3.1	3.5		4.8	9.0	10.3	1750	3210	3800	17.6	17.0	16.5
	22+28+40	2.2	2.8	4.1		4.8	9.1	10.4	1750	3190	3800	17.5	16.9	16.3
	22+28+50	2.0	2.6	4.6		4.8	9.2	10.5	1750	3180	3800	17.4	16.8	16.3
22+32+32	2.4	3.3	3.3		4.8	9.0	10.3	1750	3200	3800	17.5	16.9	16.4	
22+32+40	2.1	3.1	3.9		4.8	9.1	10.4	1750	3190	3800	17.5	16.9	16.3	
22+32+50	2.0	2.9	4.4		4.8	9.3	10.6	1750	3170	3800	17.4	16.8	16.2	

Indoor unit combination		Heating capacity (kW)							Power consumption (W)			Standard current (A)		
		Room heating capacity (kW)				Total capacity (kW)			Min.	Standard	Max.	220V	230V	240V
		A room	B room	C room	D room	Min.	Standard	Max.						
3 room	22+40+40	2.0	3.6	3.6		4.8	9.2	10.6	1750	3170	3800	17.4	16.8	16.2
	22+40+50	1.8	3.4	4.2		4.8	9.4	10.7	1750	3160	3800	17.3	16.7	16.2
	25+25+25	2.97	2.97	2.97		4.8	8.9	10.2	1750	3220	3800	17.6	17.0	16.5
	25+25+28	2.9	2.9	3.1		4.8	8.9	10.2	1750	3210	3800	17.6	17.0	16.5
	25+25+32	2.7	2.7	3.6		4.8	9.0	10.3	1750	3210	3800	17.6	17.0	16.5
	25+25+40	2.5	2.5	4.1		4.8	9.1	10.4	1750	3190	3800	17.5	16.9	16.3
	25+25+50	2.3	2.3	4.6		4.8	9.2	10.5	1750	3180	3800	17.4	16.8	16.3
	25+28+28	2.8	3.1	3.1		4.8	9.0	10.3	1750	3210	3800	17.6	17.0	16.5
	25+28+32	2.6	3.0	3.4		4.8	9.0	10.3	1750	3200	3800	17.5	16.9	16.4
	25+28+40	2.4	2.7	4.0		4.8	9.1	10.4	1750	3190	3800	17.5	16.9	16.3
	25+28+50	2.3	2.5	4.5		4.8	9.3	10.6	1750	3170	3800	17.4	16.8	16.2
	25+32+32	2.5	3.3	3.3		4.8	9.1	10.4	1750	3190	3800	17.5	16.9	16.3
	25+32+40	2.4	3.0	3.8		4.8	9.2	10.5	1750	3180	3800	17.4	16.8	16.3
	25+32+50	2.2	2.8	4.3		4.8	9.3	10.6	1750	3160	3800	17.3	16.7	16.2
	25+40+40	2.3	3.5	3.5		4.8	9.3	10.6	1750	3170	3800	17.4	16.8	16.2
	25+40+50	2.0	3.3	4.1		4.8	9.4	10.7	1750	3150	3800	17.3	16.7	16.1
	28+28+28	3.0	3.0	3.0		4.8	9.0	10.3	1750	3200	3800	17.5	16.9	16.4
	28+28+32	2.9	2.9	3.3		4.8	9.1	10.4	1750	3200	3800	17.5	16.9	16.4
	28+28+40	2.7	2.7	3.8		4.8	9.2	10.5	1750	3180	3800	17.4	16.8	16.3
	28+28+50	2.5	2.5	4.3		4.8	9.3	10.6	1750	3170	3800	17.4	16.8	16.2
28+32+32	2.7	3.2	3.2		4.8	9.1	10.4	1750	3190	3800	17.5	16.9	16.3	
28+32+40	2.6	2.9	3.7		4.8	9.2	10.5	1750	3180	3800	17.4	16.8	16.3	
28+32+50	2.4	2.7	4.2		4.8	9.3	10.7	1750	3160	3800	17.3	16.7	16.2	
28+40+40	2.5	3.4	3.4		4.8	9.3	10.6	1750	3160	3800	17.3	16.7	16.2	
28+40+50	2.2	3.2	4.0		4.8	9.4	10.8	1750	3140	3800	17.2	16.6	16.1	
32+32+32	3.07	3.07	3.07		4.8	9.2	10.5	1750	3180	3800	17.4	16.8	16.3	
32+32+40	2.9	2.9	3.5		4.8	9.3	10.6	1750	3170	3800	17.4	16.8	16.2	
32+32+50	2.6	2.6	4.2		4.8	9.4	10.7	1750	3150	3800	17.3	16.7	16.1	
32+40+40	2.6	3.4	3.4		4.8	9.4	10.7	1750	3160	3800	17.3	16.7	16.2	
40+40+40	3.17	3.17	3.17		4.8	9.5	10.8	1750	3140	3800	17.2	16.6	16.1	
4 room	22+22+22+22	2.28	2.28	2.28	2.28	5.6	9.1	10.4	1900	3200	3800	17.5	16.9	16.4
	22+22+22+25	2.2	2.2	2.2	2.5	5.6	9.1	10.4	1900	3190	3800	17.5	16.9	16.3
	22+22+22+28	2.1	2.1	2.1	2.8	5.6	9.1	10.4	1900	3190	3800	17.5	16.9	16.3
	22+22+22+32	2.1	2.1	2.1	2.9	5.6	9.2	10.5	1900	3180	3800	17.4	16.8	16.3
	22+22+22+40	1.9	1.9	1.9	3.6	5.6	9.3	10.6	1900	3170	3800	17.4	16.8	16.2
	22+22+22+50	1.8	1.8	1.8	4.0	5.6	9.4	10.8	1900	3150	3800	17.3	16.7	16.1
	22+22+25+25	2.15	2.15	2.4	2.4	5.6	9.1	10.4	1900	3190	3800	17.5	16.9	16.3
	22+22+25+28	2.1	2.1	2.4	2.6	5.6	9.2	10.5	1900	3180	3800	17.4	16.8	16.3
	22+22+25+32	2.0	2.0	2.3	2.9	5.6	9.2	10.5	1900	3170	3800	17.4	16.8	16.2
	22+22+25+40	1.9	1.9	2.1	3.4	5.6	9.3	10.7	1900	3160	3800	17.3	16.7	16.2
	22+22+25+50	1.8	1.8	2.0	3.9	5.6	9.5	10.8	1900	3140	3800	17.2	16.6	16.1
	22+22+28+28	2.0	2.0	2.6	2.6	5.6	9.2	10.5	1900	3180	3800	17.4	16.8	16.3
	22+22+28+32	2.0	2.0	2.5	2.8	5.6	9.3	10.6	1900	3170	3800	17.4	16.8	16.2
	22+22+28+40	1.8	1.8	2.4	3.4	5.6	9.4	10.7	1900	3160	3800	17.3	16.7	16.2
	22+22+32+32	1.9	1.9	2.75	2.75	5.6	9.3	10.6	1900	3160	3800	17.3	16.7	16.2
	22+22+32+40	1.8	1.8	2.6	3.2	5.6	9.4	10.8	1900	3150	3800	17.3	16.7	16.1
	22+25+25+25	2.0	2.4	2.4	2.4	5.6	9.2	10.5	1900	3180	3800	17.4	16.8	16.3
	22+25+25+28	2.0	2.3	2.3	2.6	5.6	9.2	10.5	1900	3180	3800	17.4	16.8	16.3
	22+25+25+32	2.0	2.2	2.2	2.9	5.6	9.3	10.6	1900	3170	3800	17.4	16.8	16.2
	22+25+25+40	1.8	2.1	2.1	3.4	5.6	9.4	10.7	1900	3160	3800	17.3	16.7	16.2
22+25+28+28	2.0	2.3	2.3	2.5	5.6	9.3	10.6	1900	3170	3800	17.4	16.8	16.2	
22+25+28+32	1.9	2.2	2.4	2.8	5.6	9.3	10.6	1900	3160	3800	17.3	16.7	16.2	
22+25+28+40	1.8	2.0	2.3	3.3	5.6	9.4	10.7	1900	3150	3800	17.3	16.7	16.1	
22+25+32+32	1.9	2.1	2.7	2.7	5.6	9.4	10.7	1900	3160	3800	17.3	16.7	16.2	
22+25+32+40	1.8	2.0	2.6	3.1	5.6	9.5	10.8	1900	3140	3800	17.2	16.6	16.1	

Indoor unit combination		Heating capacity (kW)							Power consumption (W)			Standard current (A)		
		Room heating capacity (kW)				Total capacity (kW)			Min.	Standard	Max.	220V	230V	240V
		A room	B room	C room	D room	Min.	Standard	Max.						
4 room	22+28+28+28	1.8	2.5	2.5	2.5	5.6	9.3	10.6	1900	3170	3800	17.4	16.8	16.2
	22+28+28+32	1.8	2.4	2.4	2.7	5.6	9.3	10.7	1900	3160	3800	17.3	16.7	16.2
	22+28+28+40	1.8	2.2	2.2	3.2	5.6	9.4	10.8	1900	3140	3800	17.2	16.6	16.1
	22+28+32+32	1.9	2.3	2.6	2.6	5.6	9.4	10.7	1900	3150	3800	17.3	16.7	16.1
	22+32+32+32	1.9	2.5	2.5	2.5	5.6	9.4	10.8	1900	3140	3800	17.2	16.6	16.1
	25+25+25+25	2.3	2.3	2.3	2.3	5.6	9.2	10.5	1900	3180	3800	17.4	16.8	16.3
	25+25+25+28	2.3	2.3	2.3	2.4	5.6	9.3	10.6	1900	3170	3800	17.4	16.8	16.2
	25+25+25+32	2.2	2.2	2.2	2.7	5.6	9.3	10.6	1900	3160	3800	17.3	16.7	16.2
	25+25+25+40	2.0	2.0	2.0	3.4	5.6	9.4	10.7	1900	3150	3800	17.3	16.7	16.1
	25+25+28+28	2.2	2.2	2.45	2.45	5.6	9.3	10.6	1900	3170	3800	17.4	16.8	16.2
	25+25+28+32	2.1	2.1	2.4	2.7	5.6	9.3	10.7	1900	3160	3800	17.3	16.7	16.2
	25+25+28+40	2.0	2.0	2.2	3.2	5.6	9.4	10.8	1900	3140	3800	17.2	16.6	16.1
	25+25+32+32	2.1	2.1	2.6	2.6	5.6	9.4	10.7	1900	3150	3800	17.3	16.7	16.1
	25+28+28+28	2.1	2.4	2.4	2.4	5.6	9.3	10.7	1900	3160	3800	17.3	16.7	16.2
	25+28+28+32	2.1	2.3	2.3	2.7	5.6	9.4	10.7	1900	3150	3800	17.3	16.7	16.1
	25+28+32+32	2.0	2.2	2.6	2.6	5.6	9.4	10.8	1900	3150	3800	17.3	16.7	16.1
	28+28+28+28	2.35	2.35	2.35	2.35	5.6	9.4	10.7	1900	3160	3800	17.3	16.7	16.2
28+28+28+32	2.3	2.3	2.3	2.5	5.6	9.4	10.8	1900	3150	3800	17.3	16.7	16.1	
28+28+32+32	2.2	2.2	2.55	2.55	5.6	9.5	10.8	1900	3140	3800	17.2	16.6	16.1	

(b) Cooling

Indoor unit combination		Cooling capacity (kW)							Power consumption (W)			Standard current (A)		
		Room cooling capacity (kW)				Total capacity (kW)			Min.	Standard	Max.	220V	230V	240V
		A room	B room	C room	D room	Min.	Standard	Max.						
1 room	22	2.2				1.8	2.2	2.5	750	860	1020	4.7	4.5	4.3
	25	2.5				1.8	2.5	2.8	750	980	1140	5.4	5.2	4.9
	28	2.8				2.2	2.8	3.0	920	1100	1230	6.1	5.8	5.5
	32	3.2				2.2	3.2	3.5	920	1250	1420	6.9	6.6	6.3
	40	4.0				2.6	4.0	4.5	1080	1560	1830	8.6	8.2	7.8
	50	5.0				2.6	5.0	5.6	1080	1950	2270	10.7	10.3	9.8
2 room	22+22	2.2	2.2			3.0	4.4	5.0	1250	1720	2030	9.5	9.0	8.6
	22+25	2.2	2.5			3.0	4.7	5.3	1250	1840	2160	10.1	9.7	9.2
	22+28	2.2	2.8			3.0	5.0	5.6	1250	1950	2270	10.7	10.3	9.8
	22+32	2.2	3.2			3.0	5.4	6.0	1250	2110	2440	11.6	11.1	10.6
	22+40	2.2	4.0			3.0	6.2	6.8	1250	2420	2760	13.3	12.7	12.1
	22+50	2.1	4.9			3.0	7.0	7.6	1250	2810	3180	15.5	14.8	14.1
	25+25	2.5	2.5			3.0	5.0	5.6	1250	1950	2270	10.7	10.3	9.8
	25+28	2.5	2.8			3.0	5.3	5.9	1250	2070	2400	11.4	10.9	10.4
	25+32	2.5	3.2			3.0	5.7	6.3	1250	2220	2550	12.2	11.7	11.1
	25+40	2.5	4.0			3.0	6.5	7.1	1250	2540	2890	14.0	13.4	12.7
	25+50	2.4	4.7			3.0	7.1	7.7	1250	2930	3310	16.1	15.4	14.7
	28+28	2.8	2.8			3.0	5.6	6.2	1250	2180	2510	12.0	11.5	10.9
	28+32	2.8	3.2			3.0	6.0	6.6	1250	2340	2680	12.9	12.3	11.7
	28+40	2.8	4.0			3.0	6.8	7.4	1250	2660	3010	14.6	14.0	13.3
	28+50	2.6	4.6			3.0	7.2	7.8	1250	3000	3390	16.5	15.8	15.0
	32+32	3.2	3.2			3.0	6.4	7.0	1250	2500	2850	13.8	13.1	12.5
	32+40	3.1	3.9			3.0	7.0	7.6	1250	2810	3180	15.5	14.8	14.1
	32+50	2.8	4.4			3.0	7.2	7.8	1250	3020	3420	16.6	15.9	15.1
40+40	3.6	3.6			3.0	7.2	7.8	1250	3020	3420	16.6	15.9	15.1	
40+50	3.3	4.1			3.0	7.4	8.0	1250	3080	3470	16.9	16.2	15.4	
50+50	3.8	3.8			3.0	7.6	8.2	1250	3140	3530	17.3	16.5	15.7	

Indoor unit combination	Cooling capacity (kW)							Power consumption (W)			Standard current (A)		
	Room cooling capacity (kW)				Total capacity (kW)			Min.	Standard	Max.	220V	230V	240V
	A room	B room	C room	D room	Min.	Standard	Max.						
22+22+22	2.2	2.2	2.2		4.2	6.6	7.2	1750	2580	2930	14.2	13.6	12.9
22+22+25	2.2	2.2	2.5		4.2	6.9	7.5	1750	2700	3050	14.9	14.2	13.5
22+22+28	2.1	2.1	2.8		4.2	7.0	7.6	1750	2810	3180	15.5	14.8	14.1
22+22+32	2.1	2.1	2.9		4.2	7.1	7.7	1750	2970	3360	16.3	15.6	14.9
22+22+40	1.9	1.9	3.5		4.2	7.3	7.9	1750	3040	3430	16.7	16.0	15.2
22+22+50	1.8	1.8	3.9		4.2	7.5	8.1	1750	3100	3490	17.1	16.3	15.5
22+25+25	2.2	2.4	2.4		4.2	7.0	7.6	1750	2810	3180	15.5	14.8	14.1
22+25+28	2.1	2.4	2.6		4.2	7.1	7.7	1750	2930	3310	16.1	15.4	14.7
22+25+32	2.0	2.3	2.9		4.2	7.2	7.8	1750	3000	3390	16.5	15.8	15.0
22+25+40	1.8	2.1	3.4		4.2	7.3	7.9	1750	3060	3460	16.8	16.1	15.3
22+25+50	1.7	1.9	3.9		4.2	7.5	8.1	1750	3120	3520	17.2	16.4	15.6
22+28+28	2.0	2.6	2.6		4.2	7.2	7.8	1750	3000	3390	16.5	15.8	15.0
22+28+32	1.9	2.5	2.8		4.2	7.2	7.8	1750	3020	3420	16.6	15.9	15.1
22+28+40	1.8	2.3	3.3		4.2	7.4	8.0	1750	3080	3470	16.9	16.2	15.4
22+28+50	1.7	2.1	3.8		4.2	7.6	8.2	1750	3140	3530	17.3	16.5	15.7
22+32+32	1.9	2.7	2.7		4.2	7.3	7.9	1750	3040	3430	16.7	16.0	15.2
22+32+40	1.8	2.6	3.1		4.2	7.5	8.1	1750	3100	3490	17.1	16.3	15.5
22+32+50	1.6	2.4	3.7		4.2	7.7	8.3	1750	3160	3550	17.4	16.6	15.8
22+40+40	1.6	3.0	3.0		4.2	7.6	8.2	1750	3160	3560	17.4	16.6	15.8
22+40+50	1.5	2.8	3.5		4.2	7.8	8.4	1750	3220	3620	17.7	16.9	16.1
25+25+25	2.4	2.4	2.4		4.2	7.2	7.7	1750	2930	3310	16.1	15.4	14.7
25+25+28	2.3	2.3	2.6		4.2	7.2	7.8	1750	3000	3390	16.5	15.8	15.0
25+25+32	2.2	2.2	2.8		4.2	7.2	7.8	1750	3020	3420	16.6	15.9	15.1
25+25+40	2.1	2.1	3.2		4.2	7.4	8.0	1750	3080	3470	16.9	16.2	15.4
25+25+50	1.9	1.9	3.8		4.2	7.6	8.2	1750	3140	3530	17.3	16.5	15.7
25+28+28	2.2	2.5	2.5		4.2	7.2	7.8	1750	3020	3420	16.6	15.9	15.1
25+28+32	2.1	2.4	2.8		4.2	7.3	7.9	1750	3040	3430	16.7	16.0	15.2
25+28+40	2.0	2.3	3.2		4.2	7.5	8.1	1750	3100	3490	17.1	16.3	15.5
25+28+50	1.9	2.1	3.7		4.2	7.7	8.3	1750	3160	3550	17.4	16.6	15.8
25+32+32	2.0	2.7	2.7		4.2	7.4	8.0	1750	3060	3450	16.8	16.1	15.3
25+32+40	1.9	2.5	3.1		4.2	7.5	8.1	1750	3120	3520	17.2	16.4	15.6
25+32+50	1.8	2.3	3.6		4.2	7.7	8.3	1750	3180	3580	17.5	16.7	15.9
25+40+40	1.9	2.9	2.9		4.2	7.7	8.3	1750	3180	3580	17.5	16.7	15.9
25+40+50	1.7	2.7	3.5		4.2	7.9	8.5	1750	3240	3640	17.8	17.0	16.2
28+28+28	2.4	2.4	2.4		4.2	7.2	7.9	1750	3040	3430	16.7	16.0	15.2
28+28+32	2.4	2.4	2.6		4.2	7.4	8.0	1750	3060	3450	16.8	16.1	15.3
28+28+40	2.2	2.2	3.1		4.2	7.5	8.1	1750	3120	3520	17.2	16.4	15.6
28+28+50	2.0	2.0	3.7		4.2	7.7	8.3	1750	3180	3580	17.5	16.7	15.9
28+32+32	2.2	2.6	2.6		4.2	7.4	8.0	1750	3080	3470	16.9	16.2	15.4
28+32+40	2.1	2.5	3.0		4.2	7.6	8.2	1750	3140	3530	17.3	16.5	15.7
28+32+50	2.0	2.3	3.5		4.2	7.8	8.4	1750	3200	3590	17.6	16.8	16.0
28+40+40	2.0	2.9	2.9		4.2	7.8	8.4	1750	3200	3590	17.6	16.8	16.0
28+40+50	1.9	2.7	3.4		4.2	8.0	8.6	1750	3260	3650	17.9	17.1	16.3
32+32+32	2.5	2.5	2.5		4.2	7.5	8.1	1750	3120	3520	17.2	16.4	15.6
32+32+40	2.4	2.4	2.9		4.2	7.7	8.3	1750	3160	3550	17.4	16.6	15.8
32+32+50	2.2	2.2	3.5		4.2	7.9	8.5	1750	3240	3640	17.8	17.0	16.2
32+40+40	2.2	2.8	2.8		4.2	7.8	8.4	1750	3220	3620	17.7	16.9	16.1
40+40+40	2.7	2.7	2.7		4.2	8.1	8.6	1750	3270	3700	18.0	17.2	16.4

3 room

Indoor unit combination		Cooling capacity (kW)							Power consumption (W)			Standard current (A)		
		Room Cooling capacity (kW)				Total capacity (kW)			Min.	Standard	Max.	220V	230V	240V
		A room	B room	C room	D room	Min.	Standard	Max.						
4 room	22+22+22+22	1.8	1.8	1.8	1.8	5.0	7.2	8.0	2100	3060	3450	16.8	16.1	15.3
	22+22+22+25	1.8	1.8	1.8	2.0	5.0	7.4	8.0	2100	3080	3470	16.9	16.2	15.4
	22+22+22+28	1.8	1.8	1.8	2.1	5.0	7.5	8.1	2100	3100	3490	17.1	16.3	15.5
	22+22+22+32	1.7	1.7	1.7	2.5	5.0	7.6	8.2	2100	3120	3510	17.2	16.4	15.6
	22+22+22+40	1.6	1.6	1.6	2.9	5.0	7.7	8.3	2100	3180	3580	17.5	16.7	15.9
	22+22+22+50	1.5	1.5	1.5	3.4	5.0	7.9	8.5	2100	3240	3640	17.8	17.0	16.2
	22+22+25+25	1.8	1.8	2.0	2.0	5.0	7.6	8.1	2100	3100	3490	17.1	16.3	15.5
	22+22+25+28	1.7	1.7	2.0	2.2	5.0	7.6	8.1	2100	3120	3520	17.2	16.4	15.6
	22+22+25+32	1.7	1.7	1.9	2.3	5.0	7.6	8.2	2100	3140	3530	17.3	16.5	15.7
	22+22+25+40	1.6	1.6	1.8	2.8	5.0	7.8	8.4	2100	3200	3590	17.6	16.8	16.0
	22+22+25+50	1.5	1.5	1.7	2.3	5.0	8.0	8.6	2100	3270	3670	18.0	17.2	16.4
	22+22+28+28	1.7	1.7	2.1	2.1	5.0	7.6	8.2	2100	3140	3530	17.3	16.5	15.7
	22+22+28+32	1.6	1.6	2.1	2.4	5.0	7.7	8.3	2100	3160	3550	17.4	16.6	15.8
	22+22+28+40	1.5	1.5	2.0	2.8	5.0	7.8	8.4	2100	3220	3620	17.7	16.9	16.1
	22+22+32+32	1.6	1.6	2.3	2.3	5.0	7.8	8.4	2100	3200	3590	17.6	16.8	16.0
	22+22+32+40	1.5	1.5	2.2	2.7	5.0	7.9	8.5	2100	3240	3640	17.8	17.0	16.2
	22+25+25+25	1.8	1.9	1.9	1.9	5.0	7.5	8.1	2100	3120	3520	17.2	16.4	15.6
	22+25+25+28	1.7	1.9	1.9	2.1	5.0	7.6	8.2	2100	3140	3530	17.3	16.5	15.7
	22+25+25+32	1.6	1.9	1.9	2.3	5.0	7.7	8.3	2100	3160	3550	17.4	16.6	15.8
	22+25+25+40	1.5	1.7	1.7	2.9	5.0	7.8	8.4	2100	3220	3620	17.7	16.9	16.1
	22+25+28+28	1.6	1.9	2.1	2.1	5.0	7.7	8.3	2100	3160	3550	17.4	16.6	15.8
	22+25+28+32	1.6	1.8	2.0	2.3	5.0	7.7	8.3	2100	3180	3580	17.5	16.7	15.9
	22+25+28+40	1.5	1.7	1.9	2.8	5.0	7.9	8.5	2100	3240	3640	17.8	17.0	16.2
	22+25+32+32	1.5	1.9	2.2	2.2	5.0	7.8	8.4	2100	3220	3620	17.7	16.9	16.1
	22+25+32+40	1.5	1.7	2.2	2.6	5.0	8.0	8.6	2100	3270	3670	18.0	17.2	16.4
	22+28+28+28	1.7	2.0	2.0	2.0	5.0	7.7	8.3	2100	3180	3580	17.5	16.7	15.9
	22+28+28+32	1.6	2.0	2.0	2.2	5.0	7.8	8.4	2100	3200	3590	17.6	16.8	16.0
	22+28+28+40	1.5	1.9	1.9	2.7	5.0	8.0	8.6	2100	3260	3650	17.9	17.1	16.3
	22+28+32+32	1.5	1.8	2.2	2.2	5.0	7.9	8.5	2100	3240	3640	17.8	17.0	16.2
	22+32+32+32	1.4	2.2	2.2	2.2	5.0	8.0	8.6	2100	3260	3650	17.9	17.1	16.3
	25+25+25+25	1.9	1.9	1.9	1.9	5.0	7.6	8.2	2100	3140	3530	17.3	16.5	15.7
	25+25+25+28	1.9	1.9	1.9	2.0	5.0	7.7	8.3	2100	3160	3550	17.4	16.6	15.8
25+25+25+32	1.8	1.8	1.8	2.3	5.0	7.7	8.3	2100	3180	3580	17.5	16.7	15.9	
25+25+25+40	1.7	1.7	1.7	2.8	5.0	7.9	8.5	2100	3240	3640	17.8	17.0	16.2	
25+25+28+28	1.8	1.8	2.0	2.0	5.0	7.6	8.3	2100	3180	3580	17.5	16.7	15.9	
25+25+28+32	1.8	1.8	2.0	2.2	5.0	7.8	8.4	2100	3200	3590	17.6	16.8	16.0	
25+25+28+40	1.7	1.7	1.9	2.7	5.0	8.0	8.6	2100	3260	3650	17.9	17.1	16.3	
25+25+32+32	1.7	1.7	2.2	2.2	5.0	7.8	8.5	2100	3240	3630	17.8	17.0	16.2	
25+28+28+28	1.8	2.0	2.0	2.0	5.0	7.8	8.4	2100	3200	3590	17.6	16.8	16.0	
25+28+28+32	1.7	2.0	2.0	2.2	5.0	7.9	8.5	2100	3220	3610	17.7	16.9	16.1	
25+28+32+32	1.6	1.9	2.2	2.2	5.0	7.9	8.5	2100	3260	3660	17.9	17.1	16.3	
28+28+28+28	1.95	1.95	1.95	1.95	5.0	7.8	8.4	2100	3220	3620	17.7	16.9	16.1	
28+28+28+32	1.9	1.9	1.9	2.2	5.0	7.9	8.5	2100	3240	3640	17.8	17.0	16.2	
28+28+32+32	1.9	1.9	2.1	2.1	5.0	8.0	8.6	2100	3270	3700	18.0	17.2	16.4	

3.2.2 Range of usage & limitations

Item		Model	SCM80ZA
Indoor intake air temperature (Upper, lower limits)		Refer to the selection chart.	
Outdoor air temperature (Upper, lower limits)			
Indoor units that can be used in combination	Number of connected units	3 to 4 units	
	Total of indoor Units (class kW)	12kW	
Total length for all rooms		Max. 60m	
Length for one indoor unit		Max. 25m	
Difference in height between indoor and outdoor units	When above outdoor unit (B)	Max. 10m	
	When below outdoor unit (A)	Max. 15m	
Difference in height between indoor units (C)		Max. 25m	
Compressor stop/start frequency	1 cycle time	6 min or more (from stop to stop or from start to start)	
	Stop time	3 min or more	
Power source voltage	Voltage fluctuation	Within $\pm 10\%$ of rated voltage	
	Voltage drop during start	Within $\pm 15\%$ of rated voltage	
	Interval unbalance	Within $\pm 3\%$ of rated voltage	

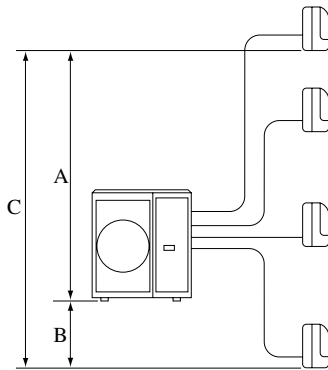

3.2.3 Exterior dimensions

(1) Indoor unit

Models SKM22ZA, 25ZA

Unit: mm

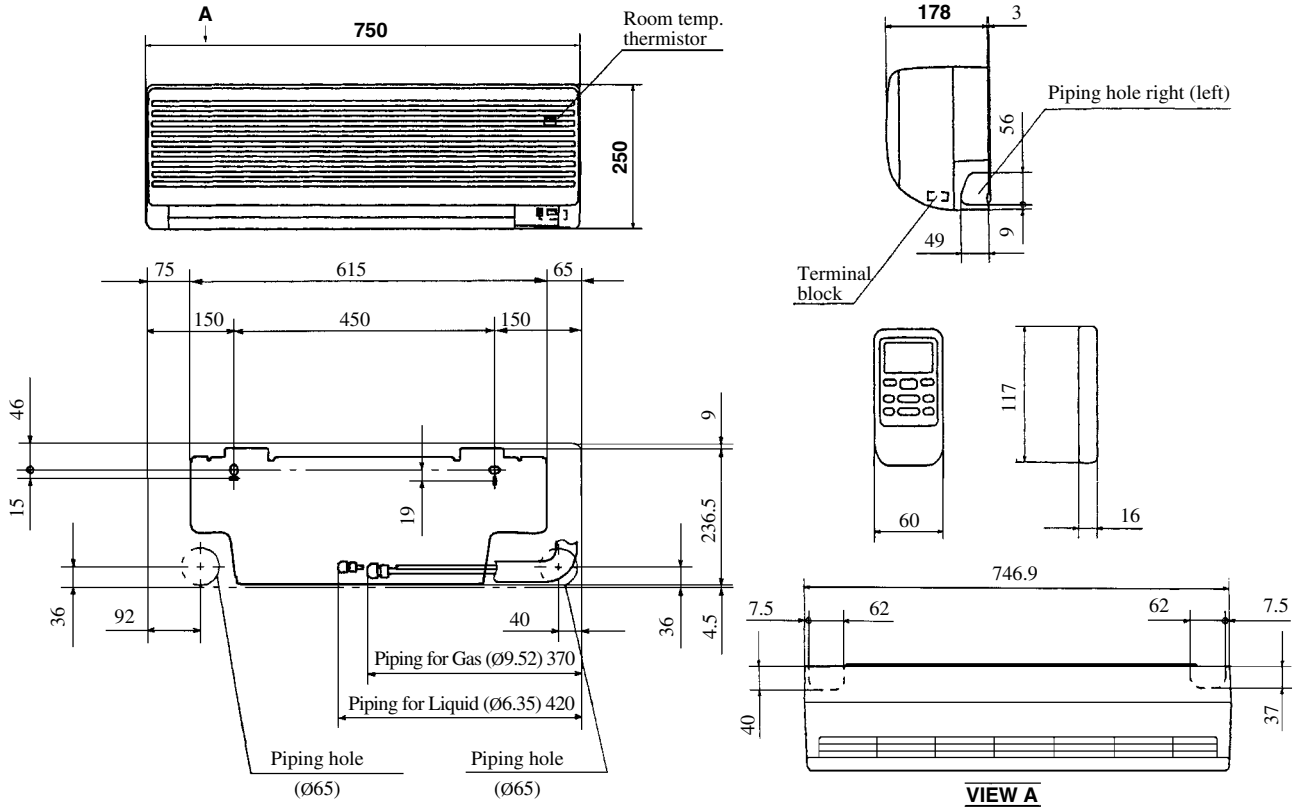

Model SKM28ZA

Unit: mm

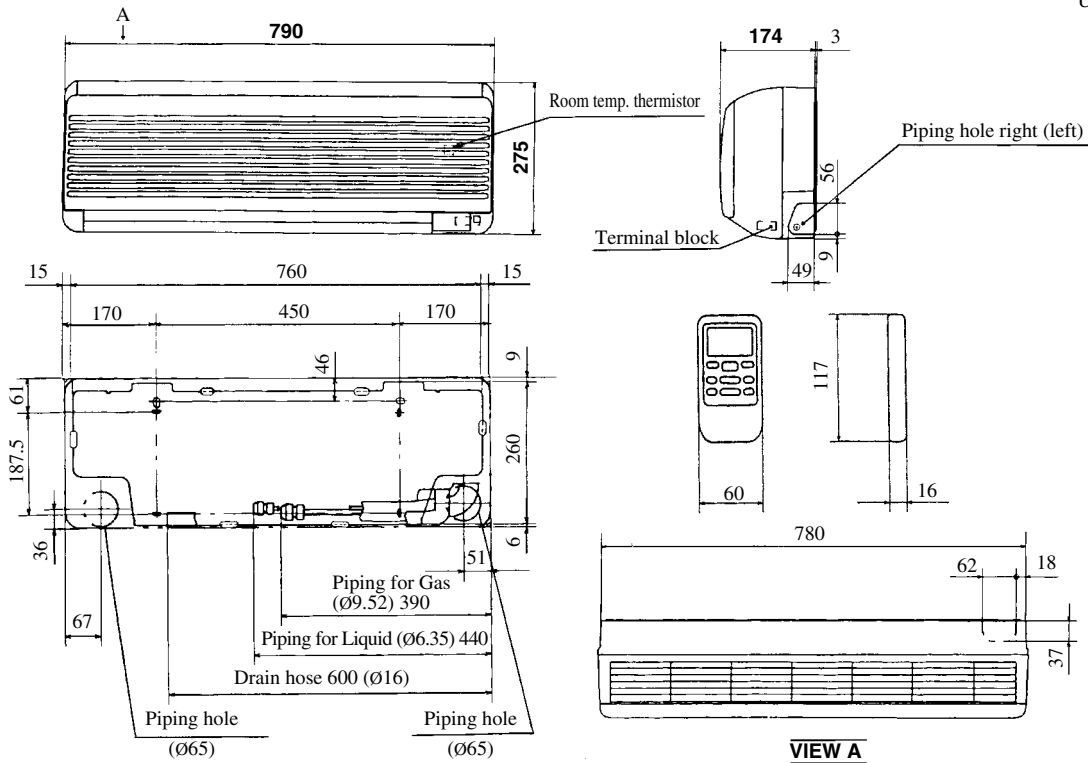

Models SKM32ZA, 40ZA

Unit: mm

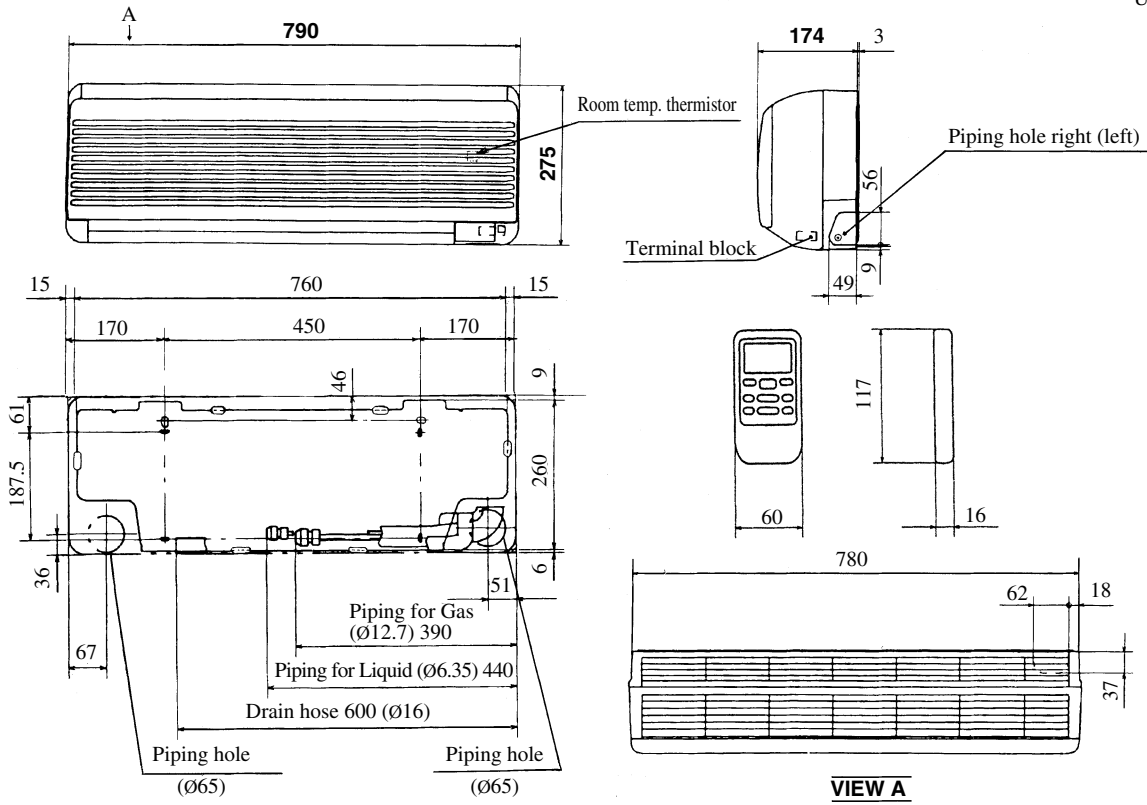

Model SKM50ZA

Unit: mm

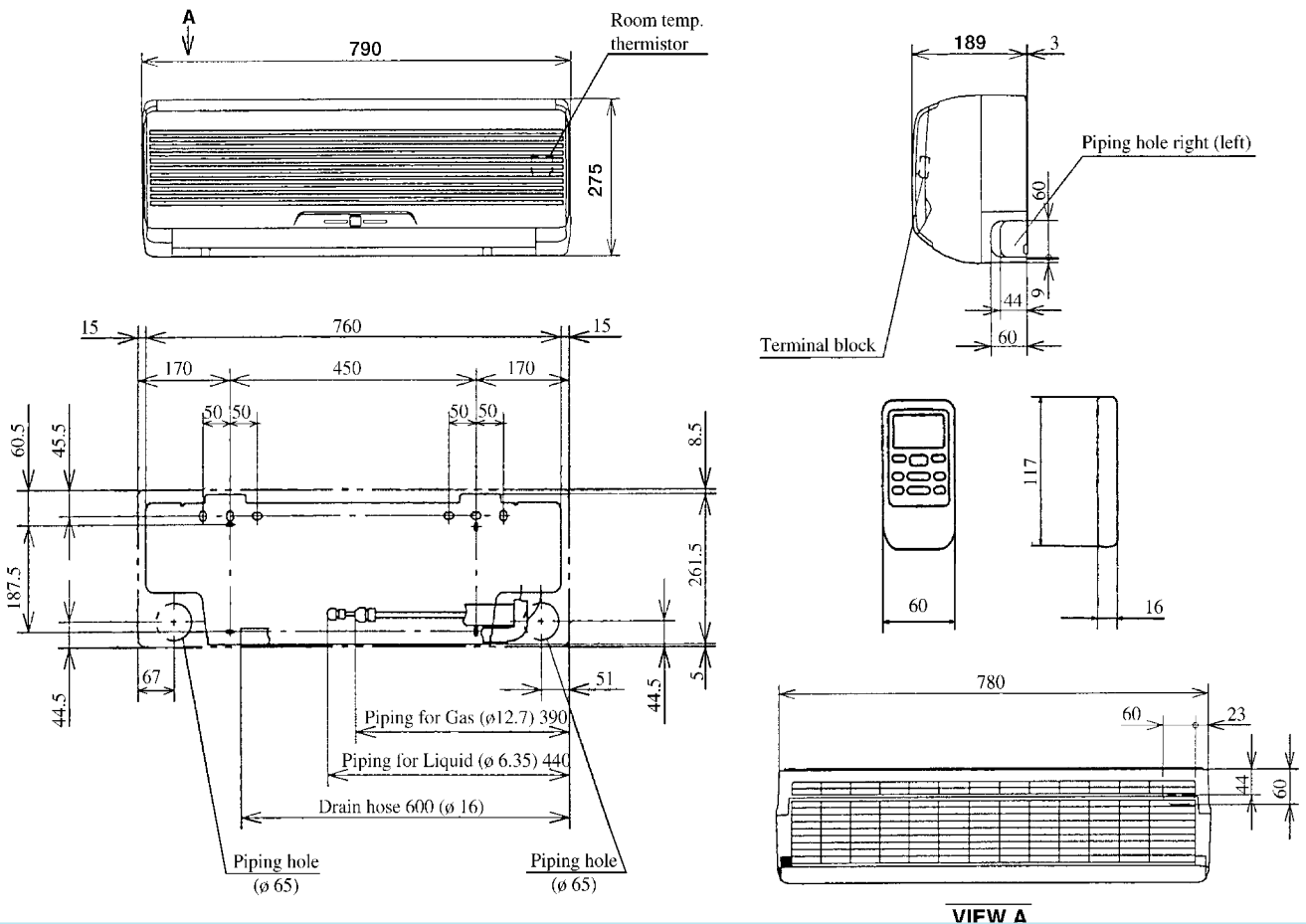

Model SRRM40ZA

Unit: mm

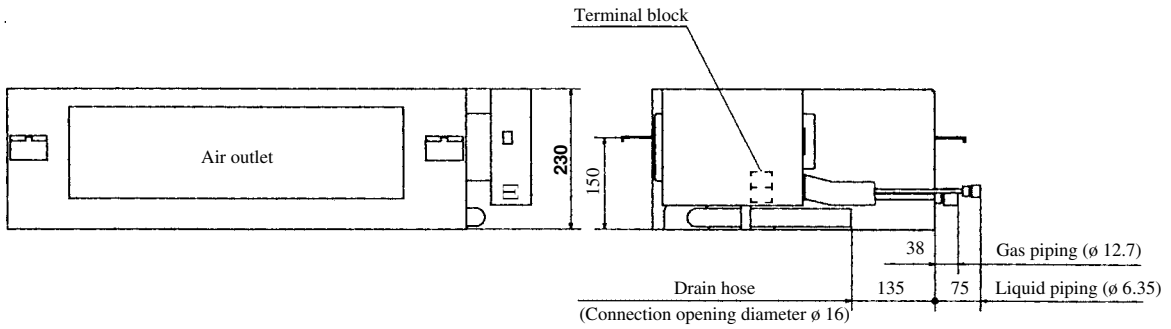
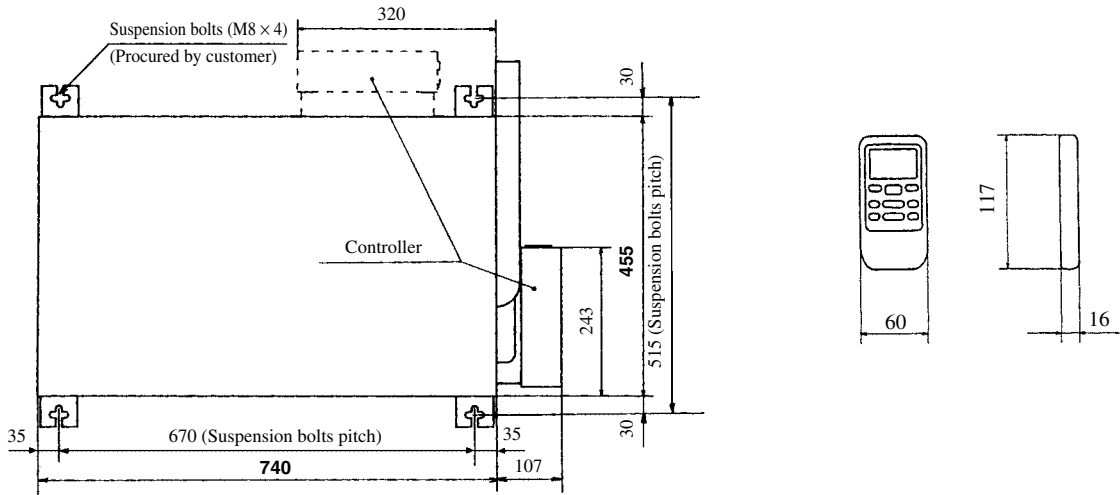

• **Details of air outlet**

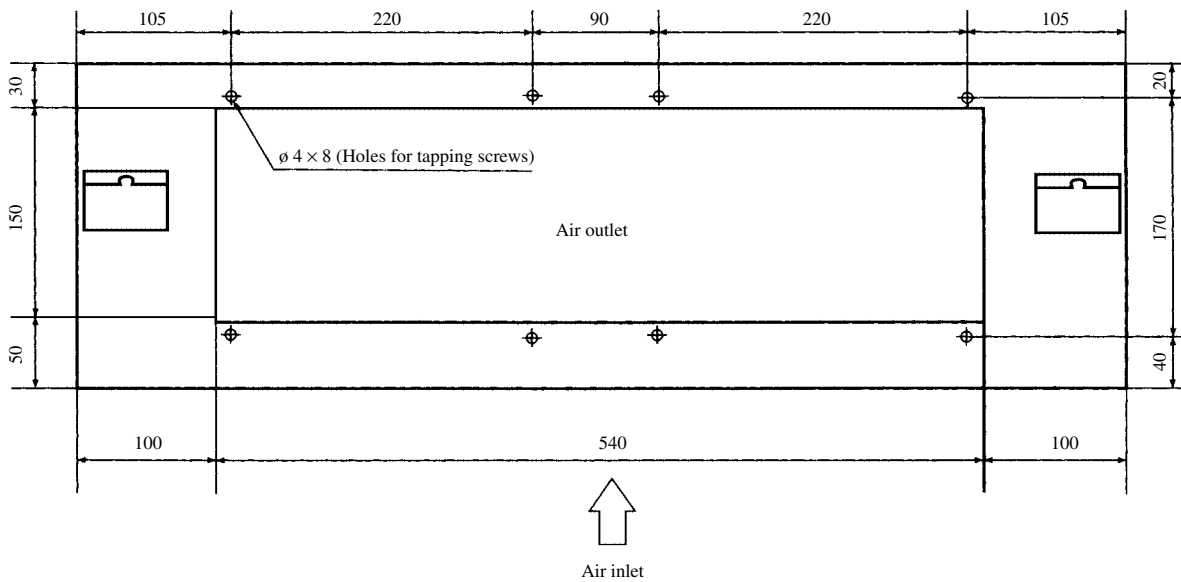

(2) Outdoor unit
Model SCM80ZA

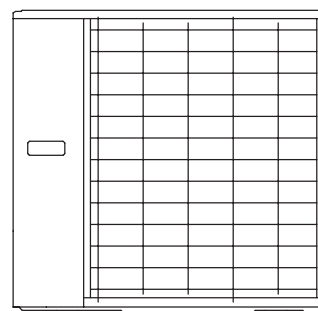
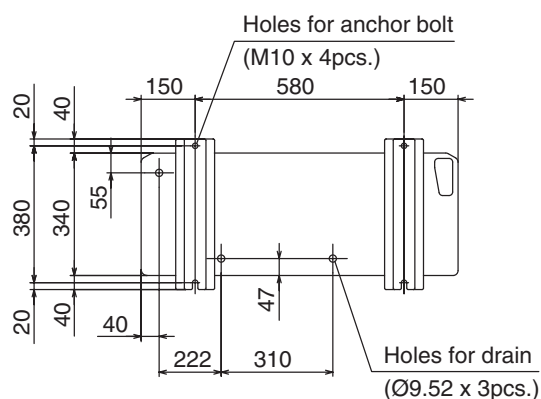
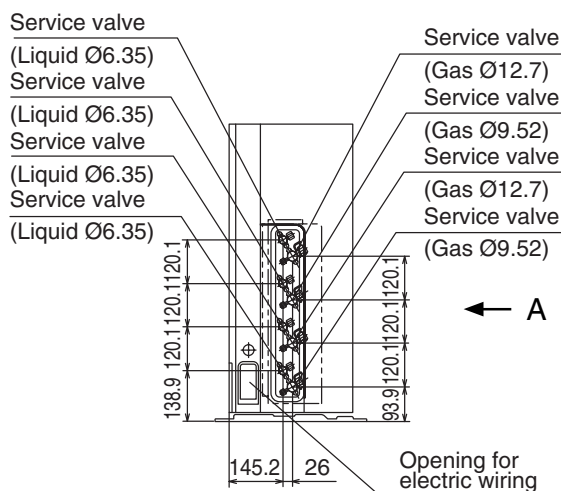
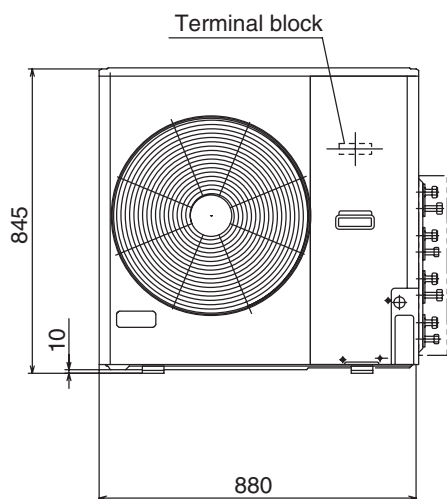
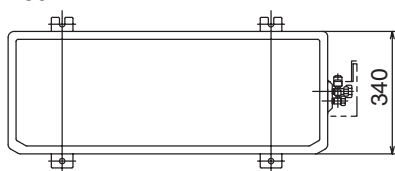

VIEW A

Required space for maintenance and air flow

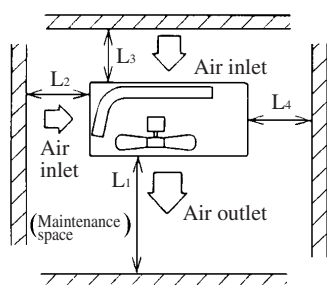

Minimum allowable space to the obstacles

Unit: mm

Mark	Installation type		
	I	II	III
L ₁	Open	Open	500
L ₂	300	50	Open
L ₃	100	150	100
L ₄	200	200	200

Notes

- (1) Avoid the location where four sides are entirely surrounded by walls.
- (2) Fix the unit by anchor bolts without fail. Restrict the protrusion length of anchor bolt to 15 mm and under.
- (3) When strong wind blows against the unit, direct the discharge port at a right angle to the wind direction.
- (4) Secure the space of 1 m and over at the top of unit.
- (5) Make the height of obstruction wall in front of discharge port lower than the height of unit.

3.2.4 Piping system

Model SCM80ZA

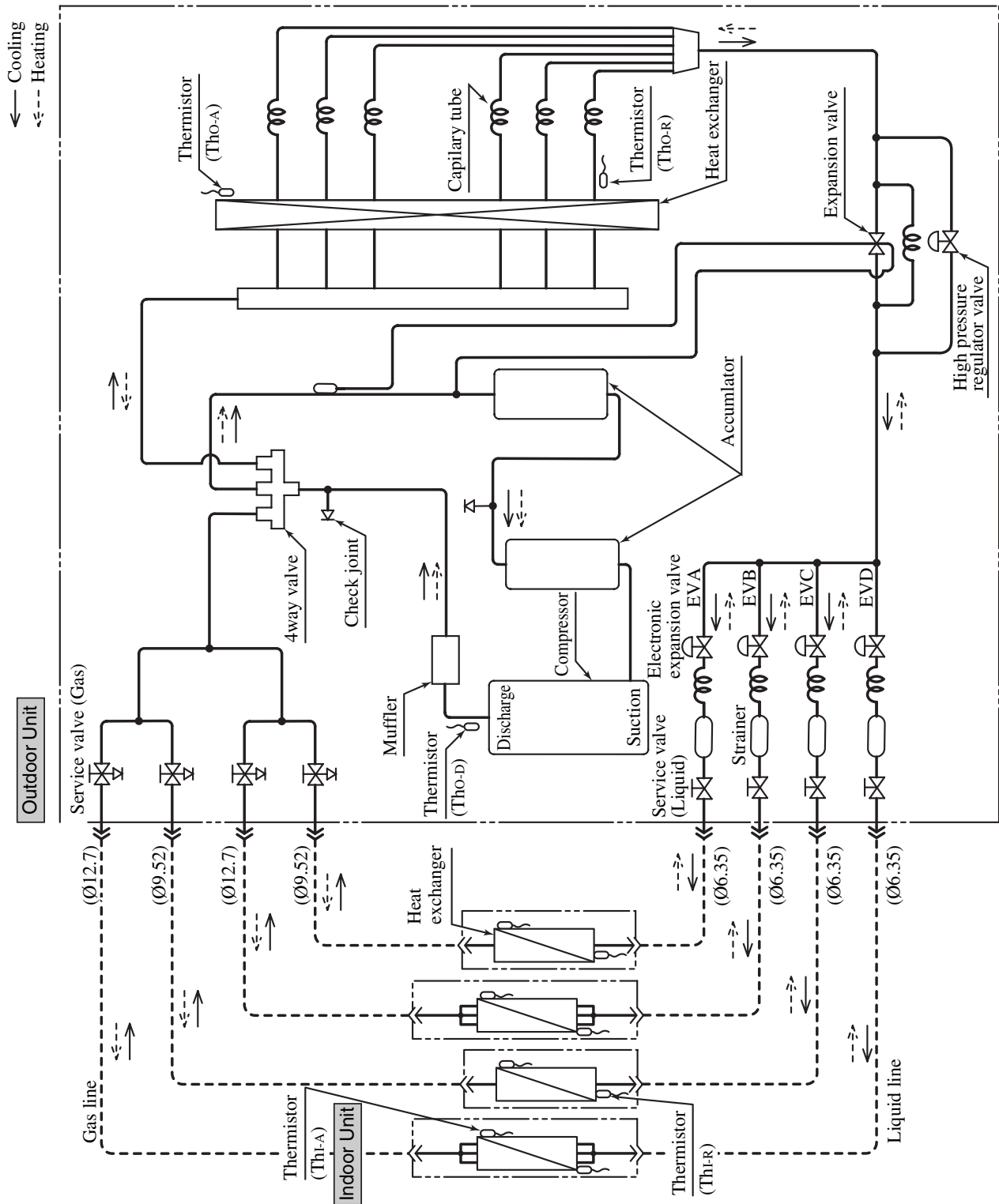

3.2.5 Selection chart

Correct the cooling and heating capacity in accordance with the conditions as follows. The net cooling and heating capacity can be obtained in the following way.

Net capacity = Capacity shown on specification × Correction factors as follows.

(1) Coefficient of cooling and heating capacity in relation to temperatures

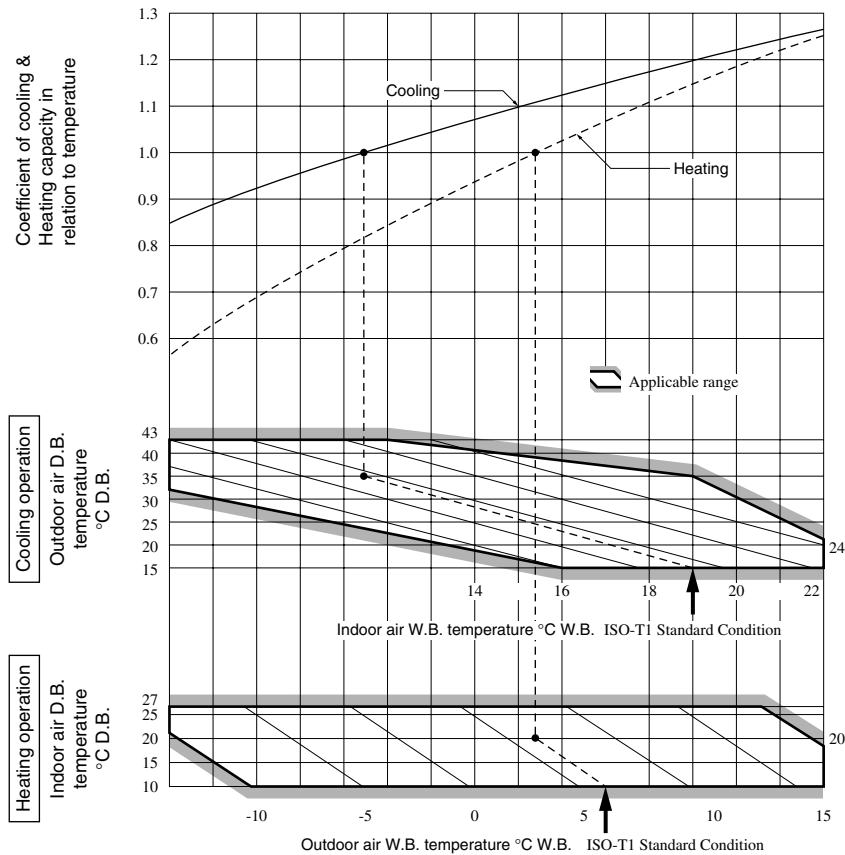

(2) Correction of cooling and heating capacity in relation to one way length of refrigerant piping

It is necessary to correct the cooling and heating capacity in relation to the one way piping length between the indoor and outdoor units.

Piping length [m]	7	10	15	20	25
Cooling	1.0	0.99	0.975	0.965	0.95
Heating	1.0	1.0	1.0	1.0	1.0

(3) Correction relative to frosting on outdoor heat exchanger during heating

In additions to the foregoing corrections (1), (2) the heating capacity needs to be adjusted also with respect to the frosting on the outdoor heat exchanger.

Air inlet temperature of outdoor unit in °CWB	-10	-9	-7	-5	-3	-1	1	3	5
Adjustment coefficient	0.95	0.94	0.93	0.91	0.88	0.86	0.87	0.92	1.00

3.3 ELECTRICAL DATA

Meaning of marks

• Outdoor Unit

Symbol	Parts name	Symbol	Parts name
CM	Compressor motor	EEVA ~ D	Electric expansion valve
C	Capacitor	20S	4 way valve (coil)
FM ₀	Fan motor	Tho-A	Thermistor (outdoor air temp.)
Re	Reactor	Tho-R	Thermistor (outdoor H.X temp.)
SA	Serge absorber	Tho-D	Thermistor (discharge temp.)
CT	Current sensor	LED5	Warning lamp (Red)
DS1, DS2	Diode stack	LED1 ~ 4	Serial signal lamp (Green)
NF	Noise filter	51C	Motor protector for CM
52X _s	Auxiliary relay		

• Indoor Unit

Symbol	Parts name	Symbol	Parts name
FM _i	Fan motor	Q	Fan motor control triac
CF _i	Capacitor (for FM _i)	F	Fuse
SM	Flap motor	Thi-A	Thermistor (room temp.)
Tr	Transformer	Thi-R	Thermistor (indoor H.X temp.)
ZNR	Varistor	52X ₁₋₅	Auxiliary relay
DM	Drain motor	Thi-H	Thermistor (humidity)
FS	Float switch		

3.3.1 Electrical wiring

(1) Indoor unit

Models SKM22ZA, 25ZA, 28ZA, 32ZA, 40ZA

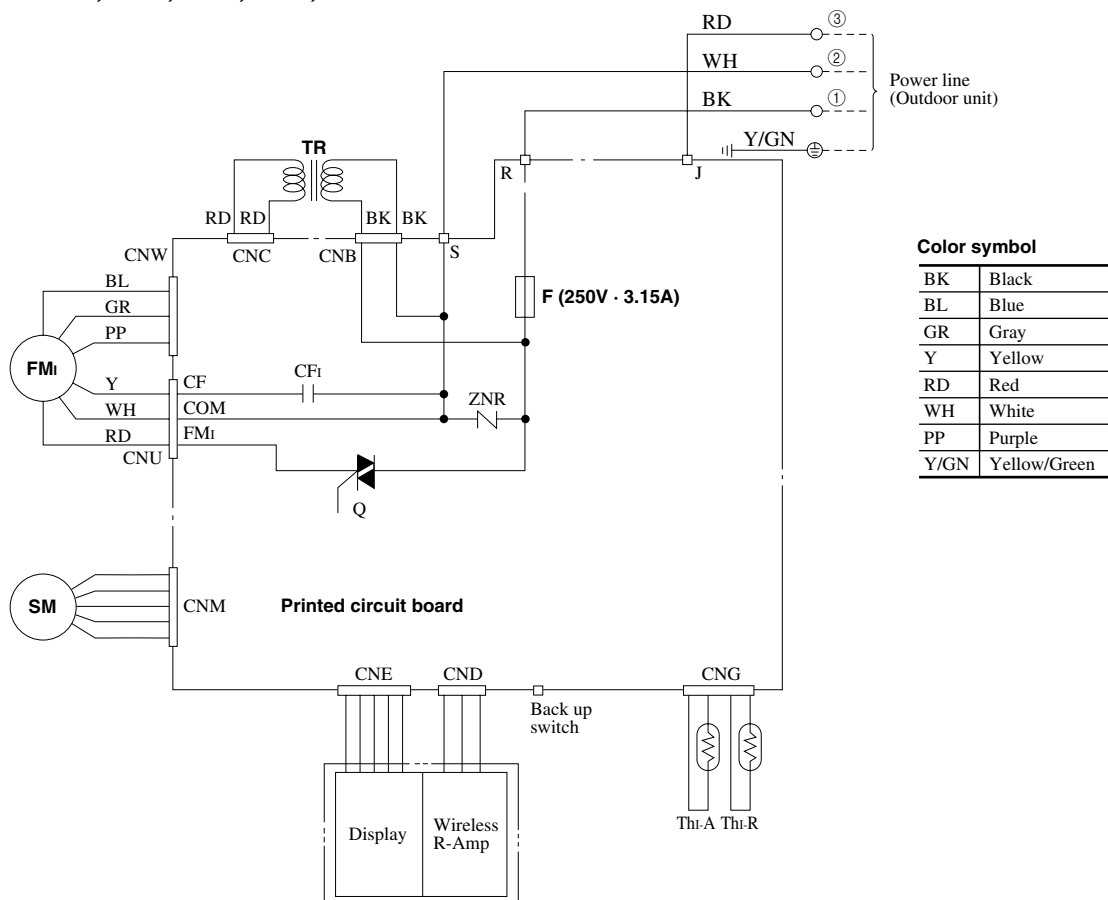

Model SKM50ZA

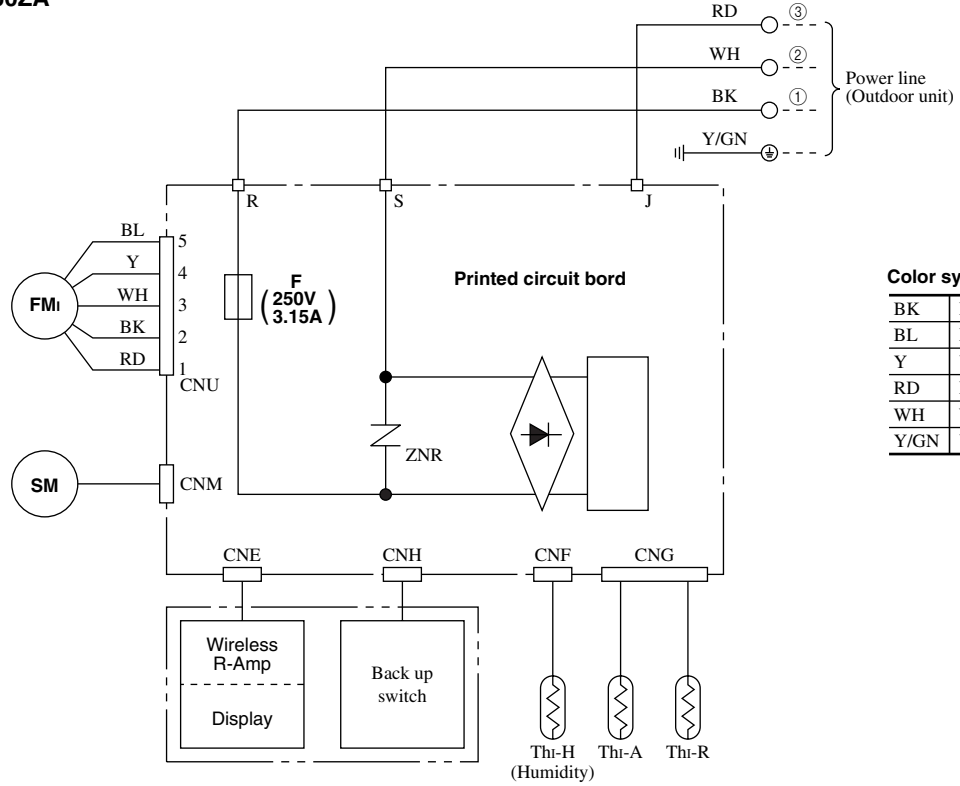

Color symbol

BK	Black
BL	Blue
Y	Yellow
RD	Red
WH	White
Y/GN	Yellow/Green

Model SRRM40ZA

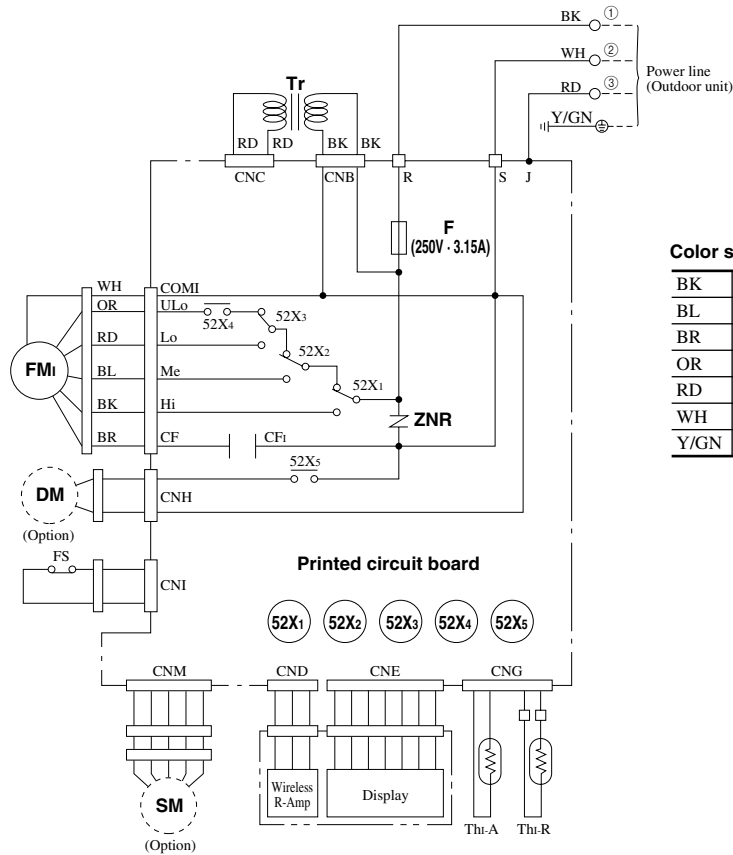

Color symbol

BK	Black
BL	Blue
BR	Brown
OR	Orange
RD	Red
WH	White
Y/GN	Yellow/Green

(2) Outdoor unit
Model SCM80ZA

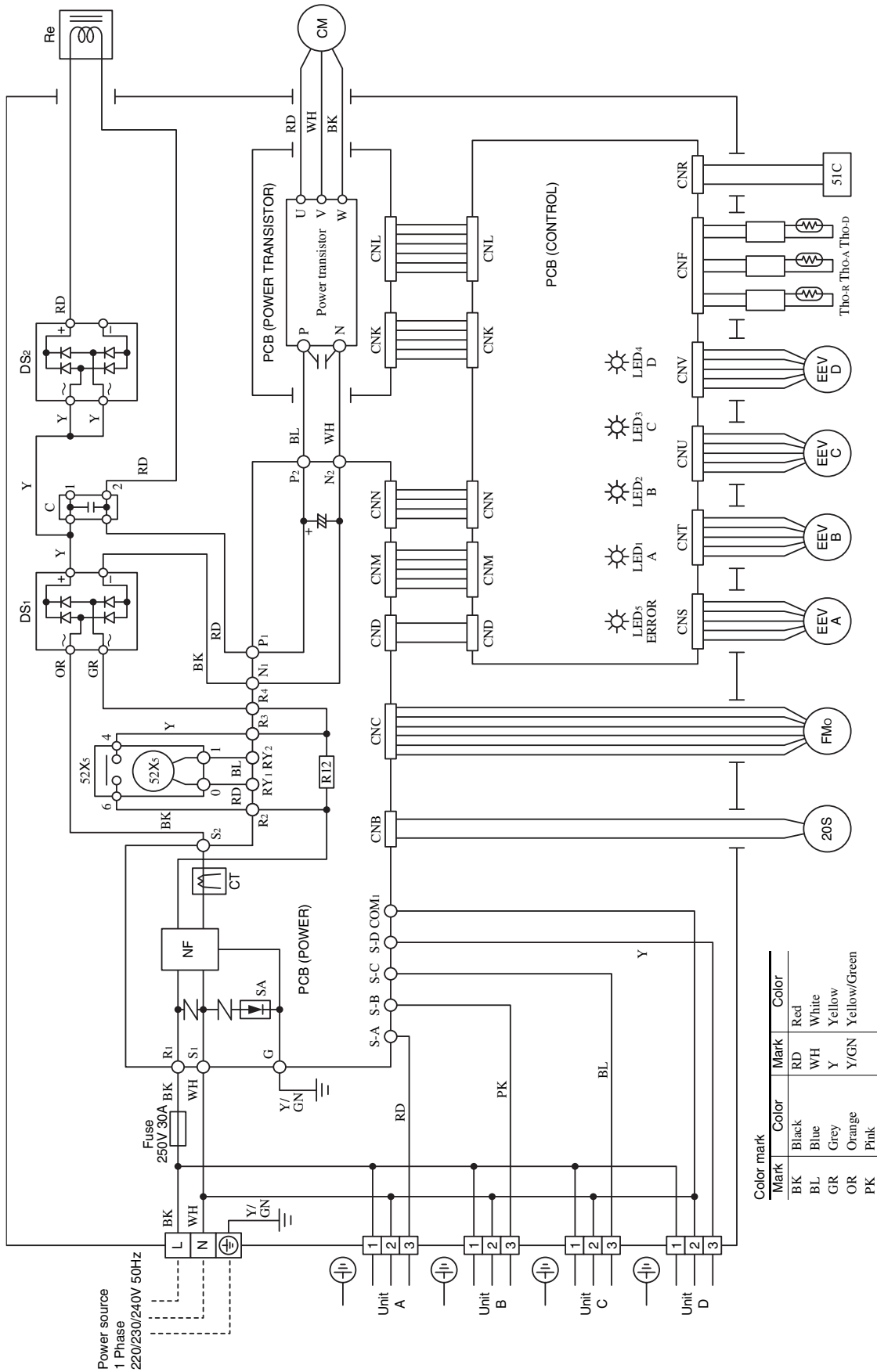

3.4 OUTLINE OF OPERATION CONTROL BY MICROCOMPUTER

(1) Remote Controller

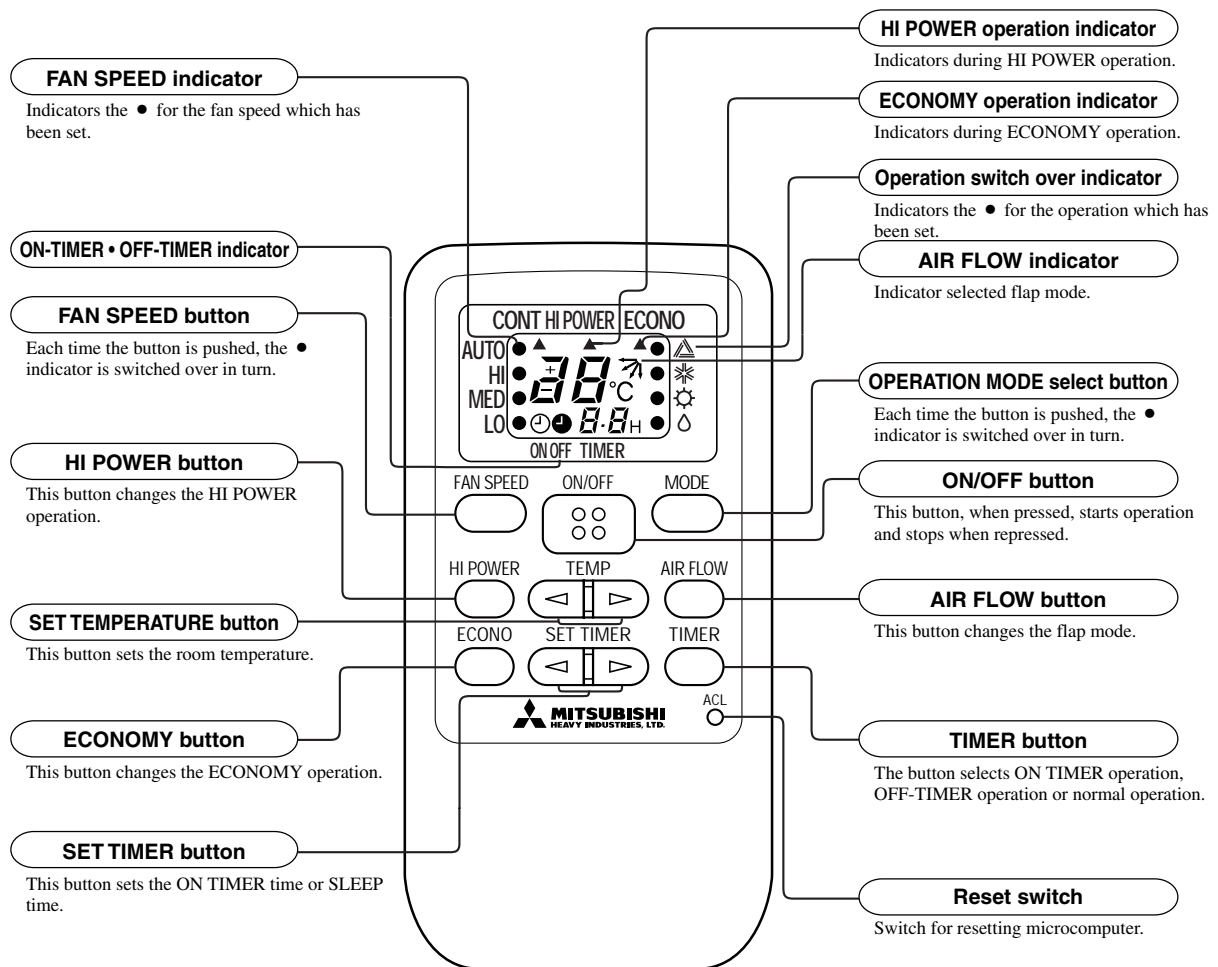

- Above figure shows all indications for the purpose of explanation, but practically only the pertinent parts are indicated.

(2) Indoor unit indicator

- SKM22, 25 models

- SKM28, 32, 40 models

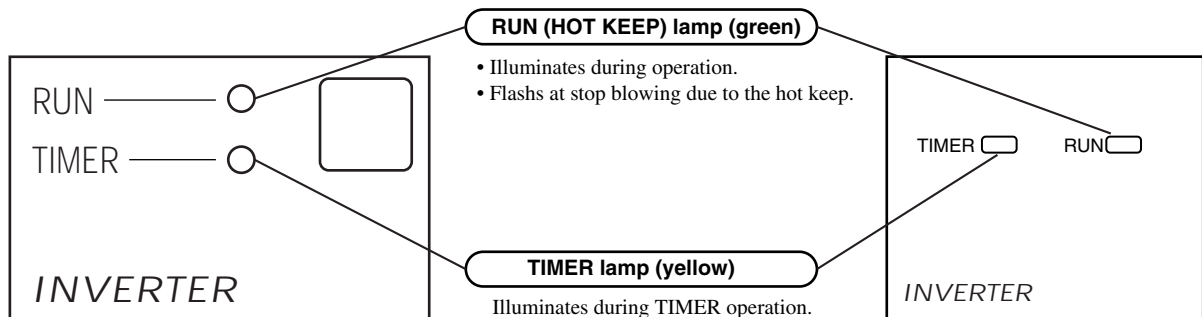

• SKM50 model

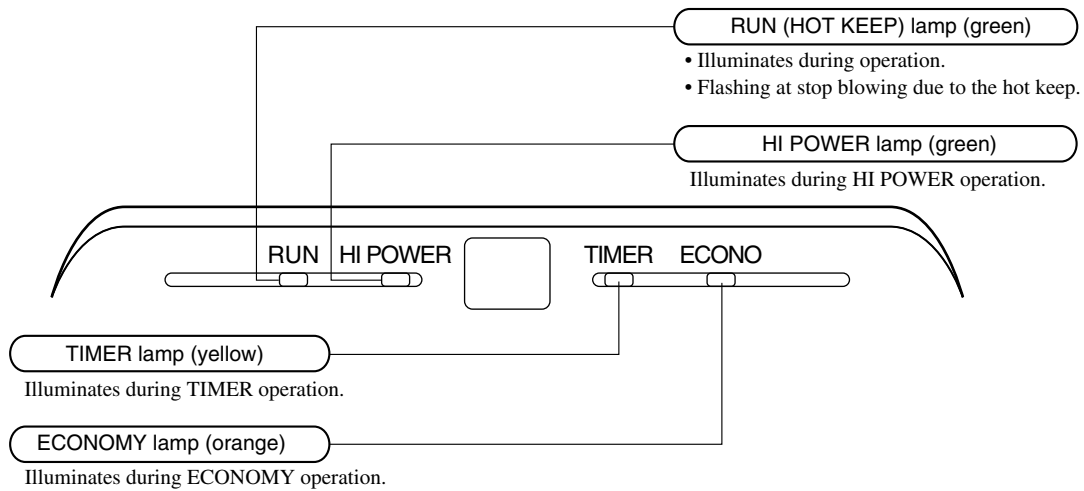

• SRRM40 model

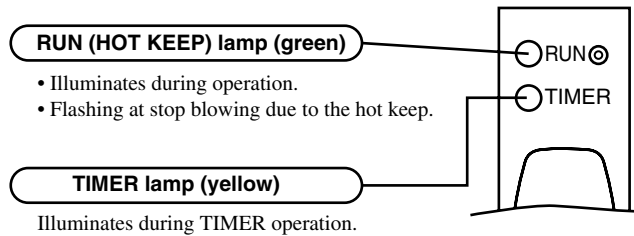

(3) Back-up switch

When the remote controller become weak, or if the remote controller is lost or malfunctioning, this switch may be used to turn the unit on and off.

(a) Operation

Push the switch once to place the unit in the automatic mode. Push it once more to turn the unit off.

(b) Detail of operation

Operation starts in the same way as the previous operation.

• SKM22, 25 models

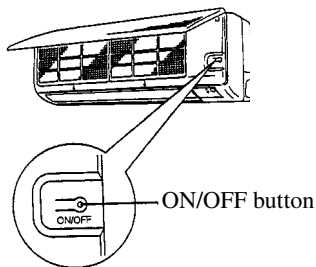

• SKM28, 32, 40 models

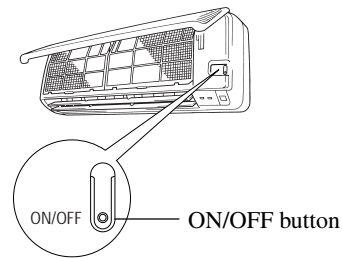

• SKM50 model

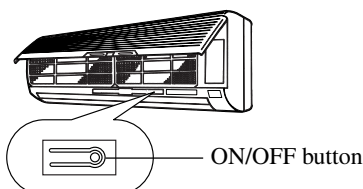

• SRRM40 model

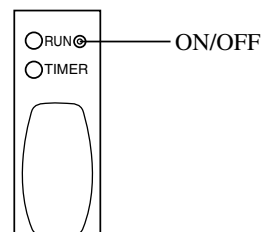

(4) Flap control

Control the flap by AIRFLOW button on the wireless remote controller.

(a) AUTO

The flap will be automatically set to the angle of air flow best to operation.

1) Starting time of operation

• SKM22, 25, 28, 32, 40 models

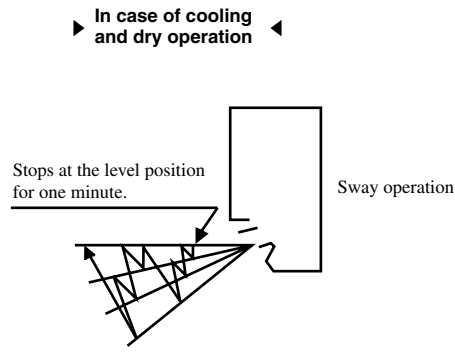

• The flap operation as shown above will be repeated.

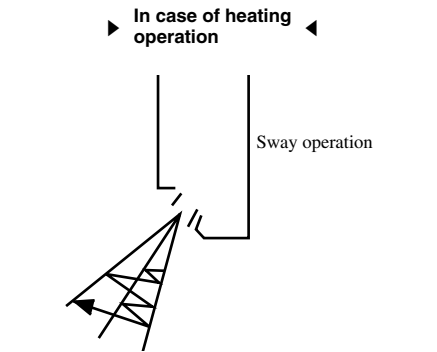

• The flap operation as shown above will be repeated.

• SKM50 model

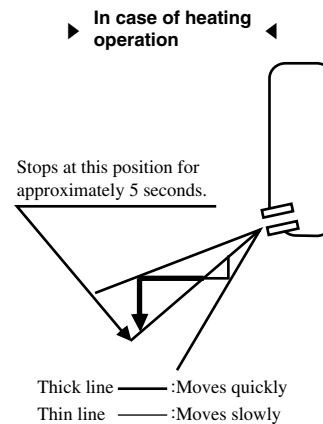
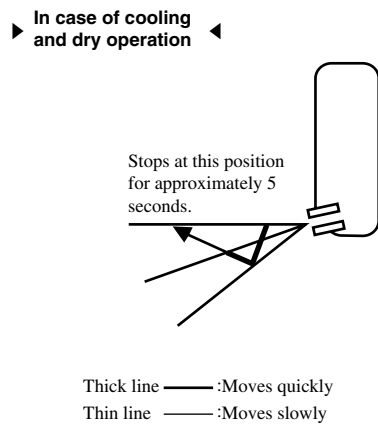

• SRRM40 model

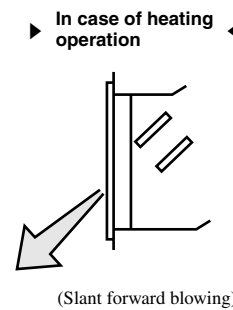
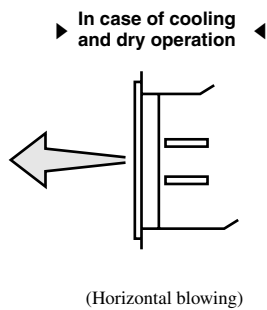

2) When not operating

The flap returns to the position of air flow directly below, when operation has stopped.

(b) Memory flap (Excepted 22, 25models)

While the flap is operating if the AIRFLOW button is pushed once, it stops swinging at an angle.

As this angle is memorized in the microcomputer, the flap will be automatically set to the angle when next operation is started.

◆ Recommendable stopping angle of the flap

- Wall mounted type

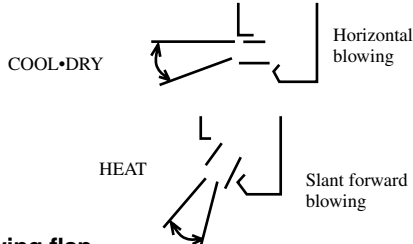

- Ceiling recessed type

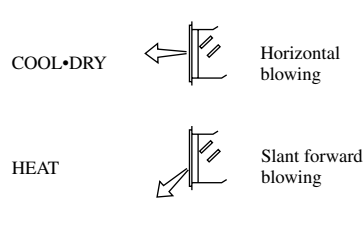

(c) Swing flap

Flap moves in upward and downward directions continuously.

- Wall mounted type

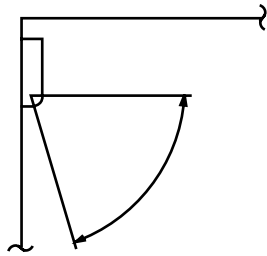

- Ceiling recessed type

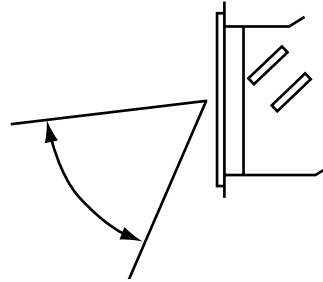

(5) Comfort timer setting

(a) SKM model

If the timer is set at ON when the operation select switch is set at the cooling or heating, or the cooling or heating in auto mode operation is selected, the comfort timer starts and determines the starting time of next operation based on the initial value of 15 minutes and the relationship between the room temperature at the setting time (temperature of room temperature sensor) and the setting temperature. (Max. 60 minutes)

Operation mode	Operation start time correction value (Min.)		
At cooling	$3 < \text{Room temp.} - \text{Setting temp.}$	$1 < \text{Room temp.} - \text{Setting temp.} \leq 3$	$\text{Room temp.} - \text{Setting temp.} \leq 1$
	+5	No change	-5
At heating	$3 < \text{Setting temp.} - \text{Room temp.}$	$2 < \text{Setting temp.} - \text{Room temp.} \leq 3$	$\text{Setting temp.} - \text{Room temp.} \leq 2$
	+5	No change	-5

- Notes (1) At 5 minutes before the timer ON time, operation starts regardless of the temperature of the room temperature sensor (Th1).
 (2) This function does not actuate when the operation select switch is set at the dehumidifying as well as the dehumidifying in the auto mode. However, the operation of item (1) above is performed during the dehumidifying in the auto mode.
 (3) During the pleasant reservation operation, both the operation lamp and timer lamp illuminate and the timer lamp goes off after expiration of the timer, ON setting time.

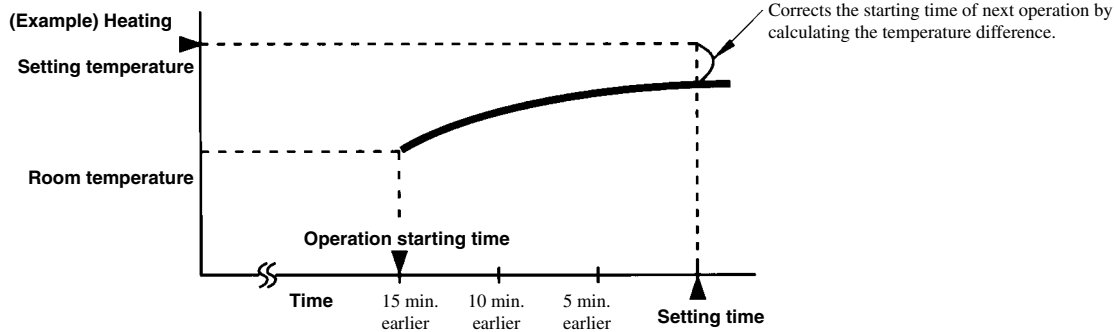

- If the difference (= Setting temperature – Room temperature) is 4°C, the correction value is found to be +5 minutes from the table shown above so that the starting time of next operation is determined as follows:

$$\underline{15 \text{ min. earlier}} + \underline{5 \text{ min.}} = 20 \text{ min. earlier}$$

Current operation Correction value

(b) SRRM model

When the timer is set to "ON" at the operation changeover is in the cooling or the heating mode, and in the cooling or the heating mode at automatic operation, the pleasant reservation timer is actuated to start by the room temperature thermistor (Th1) at 5 to 80 minutes before the set time irrespective of the time set by the timer.

Operation mode	Room. temp thermistor (Th1)	Operating start time (amount of time previous to set that operation begins)
Heating	Under 5°C	80 mins.
	Under 10°C	30 mins.
	Under 15°C	15 mins.
	Over 15°C	5 mins.
Cooling	Over 40°C	80 mins.
	Over 35°C	30 mins.
	Over 30°C	15 mins.
	Under 30°C	5 mins.

- Notes (1) At 5 minutes before the timer ON time, operation starts regardless of the temperature of the room temperature thermistor (Th1).
 (2) This function does not actuate when the operation select switch is set at the dehumidifying as well as the dehumidifying in the auto mode. However, the operation of item (1) above is performed during the dehumidifying in the auto mode.
 (3) During the pleasant reservation operation, both the operation lamp and timer lamp illuminate and the timer lamp goes off after expiration of the timer, ON setting time.

(6) Cooling operation

(a) Summary

1) Capacity control

Model	SCM80ZA
Capacity	1.8 ~ 8.6 kW

Capacity control is within the range shown above. If demand capacity of the indoor units exceeds the maximum capacity of the outdoor unit, the demand capacity will be proportionally distributed.

2) Outdoor unit frequency control (30 ~ 104Hz)

The decision frequency is based on the total indoor demand frequency as follows:

Indoor demand frequency total	Decision frequency
30 Hz or less	30 Hz
More than 30 Hz, but 104 Hz or less	30 to 104 Hz
More than 104 Hz	104 Hz

Note (1) The total indoor demand frequency is based on the value for each of the units shown in item (b).

(b) Mode switching

Within the selected mode, the unit operates using the values shown below which were obtained by multiplying a conversion coefficient to the indoor unit demand frequency.

Model (Indoor) / Operation Mode	22	25	28	32	40	50
Automatic	30	30	30 ~ 36	30 ~ 38	30 ~ 44 (30 ~ 42)	30 ~ 54
High	30	30	30 ~ 36	30 ~ 38	30 ~ 48 (30 ~ 42)	30 ~ 54
Medium	30	30	30	30	30 ~ 40 (30)	30 ~ 36
Low	30	30	30	30	30	30
Hi power	30	30	34	38	44	54
Econo	30	30	30	30	30	30

Note (1) The values in parenthesis () indicate SRRM40HENG-L.

(c) Operation of Major Functional Components in Cooling Mode

Functional components / Operation	Cooling	Thermostat OFF (All indoor units)	Thermostat OFF (Some of indoor units)	Stop, abnormal stop (Some of indoor units)	Failure (Outdoor Unit)
Demand frequency	See preceding table	0 (All indoor units)	0 (Thermostat off units)	0 (Stop, abnormal stop units)	0 (All units)
Indoor unit fan	Fixed	According to mode switching			OFF
	Automatic	According to demand frequency	According to mode switching	First speed or low	OFF
Outdoor unit fan	According to decision frequency	OFF	According to decision frequency		OFF
Electronic expansion valve (EEVA, B, C, D)	According to decision frequency	According to stop mode	All closed (Thermostat off units)	All closed (Stop, abnormal stop units)	According to stop mode
Compressor	ON	OFF	ON	ON	OFF

(7) Heating Operation

(a) Summary

1) Capacity control

Model	SCM80ZA
Capacity	2.0 ~ 10.8 kW

Capacity control is within the range shown above. If demand capacity of the indoor units exceeds the maximum capacity of the outdoor unit, the demand capacity will be proportionally distributed.

2) Outdoor unit frequency control (30 ~ 104Hz)

The decision frequency is based on the total indoor demand frequency as follows:

Indoor demand frequency total	Decision frequency
30 Hz or less	30 Hz
More than 30 Hz, but 104 Hz or less	30 to 104 Hz
More than 104 Hz	104 Hz

Note (1) The total indoor demand frequency is based on the value for each of the units shown in item (b).

(b) Mode switching

Within the selected mode, the unit operates using the values shown below which were obtained by multiplying a conversion coefficient to the indoor unit demand frequency.

Model (Indoor) Operation Mode	22	25	28	32	40	50
Automatic	30	30 ~ 32	30 ~ 48	30 ~ 50	30 ~ 54	30 ~ 60
High	30	30 ~ 32	30 ~ 48	30 ~ 50	30 ~ 54	30 ~ 60
Medium	30	30	30 ~ 34	30 ~ 36	30 ~ 50 (30 ~ 44)	30 ~ 44
Low	30	30	30	30	30	30
Hi power	30	32	48	48	50 (54)	58
Econo	30	30	30	30	30	30

Note (1) The values in parenthesis () indicate SRRM40HENG-L.

(c) Operation of Major Functional Components in Heating Mode

Functional components	Operation	Heating	Thermostat OFF (All indoor units)	Thermostat OFF (Some of indoor units)	Stop, abnormal stop (Some of indoor units)	Failure (Outdoor Unit)
Demand frequency		See preceding table	0 (All indoor units)	0 (Thermostat off units)	0 (Stop, abnormal stop units)	0 (All units)
Indoor unit fan	Fixed	According to mode switching	OFF	OFF	OFF	Hot Keep
	Automatic	According to demand frequency	OFF	OFF	OFF	Hot Keep
Outdoor unit fan		According to decision frequency	OFF	According to decision frequency		OFF
Electronic expansion valve (EVA, B, C, D)		According to decision frequency	According to stop mode	100 Pulses (Thermostat off units)	100 Pulses (Stop, abnormal stop units)	According to stop mode
Compressor		ON	OFF	ON	ON	OFF

(d) Hot Standby (When any of the following conditions is met, Hot Standby operation is activated.)

(i) Operating conditions

- ① When 4 seconds have passed since the power was turned on.
- ② Under the following conditions.
 - Ⓐ When the temperature detected by the outdoor air temperature thermistor is at the ON level as shown in the figure, and when 30 continuous minutes have passed since the decision frequency has become 0 Hz after cooling or heating has been stopped.
 - Ⓑ When 20 minutes have passed since the power was turned on and the outdoor air temperature thermistor is in the ON range.

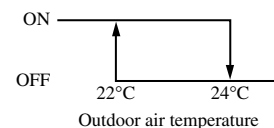

(ii) Function

Low voltage is applied from the inverter to the compressor to preheat it. This melts and vaporizes refrigerant that has frozen inside the freezer oil, making it easier for the refrigerant to circulate when the heating operation is started. This makes the start of the heating operation faster.

(iii) Finishing conditions

When at least one of the hot stand-by cut conditions described below is met during the hot stand-by function is activated, the hot stand-by function becomes inoperable.

1) When the hot stand-by function is activated during the above-mentioned condition which was described in article ① :

- ① After 20 minutes elapsed since the power ON.
- ② When the operation mode was changed from "STOP" to "COOLING" or "HEATING".

2) When the hot stand-by function is activated during the above-mentioned condition which was described in article ② :

- ① When the outer air temperature thermister entered the OFF range.
- ② When the operation mode was changed from "STOP" to "COOLING " or "HEATING".

(e) Hot keep operation

If the hot keep operation is selected during the heating operation, the indoor blower is controlled based on the temperature of the indoor unit heat exchanger (detected with Th2, indoor unit heat exchanger thermistor) to prevent blowing of cool wind.

◆ **SKM22, 25, 28, 32, 40 models**

- **Normal mode (Normal heating operation, operation after HI POWER completion)**

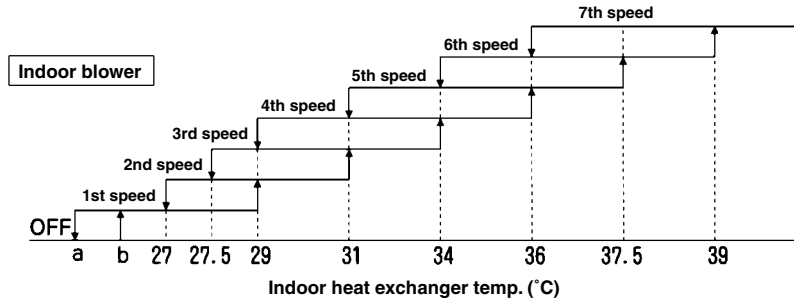

● **Values of a, b**

	a	b
At 0 Hz command	22	25
Other than 0 Hz command	17	19

Note (1) Refer to the table shown above right for the values a and b.

- **Hot keep M mode [During HI POWER operation (for 15 min.)]**

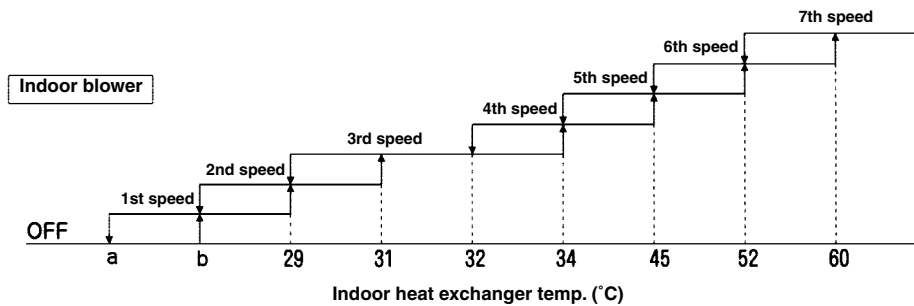

Note (1) Refer to the table shown above right for the values a and b.

◆ **SKM50 model**

- **Normal mode (Normal heating operation, operation after HI POWER completion)**

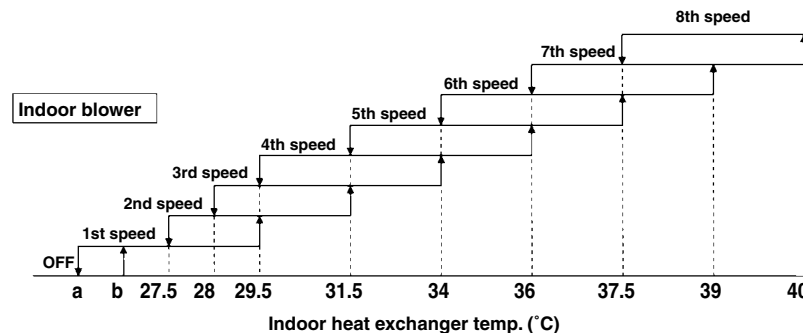

● **Values of a, b**

	a	b
At 0 Hz command	22	25
Other than 0 Hz command	17	19

Note (1) Refer to the table shown above right for the values a and b.

● Hot keep M mode [During HI POWER operation (for 15 min.)]

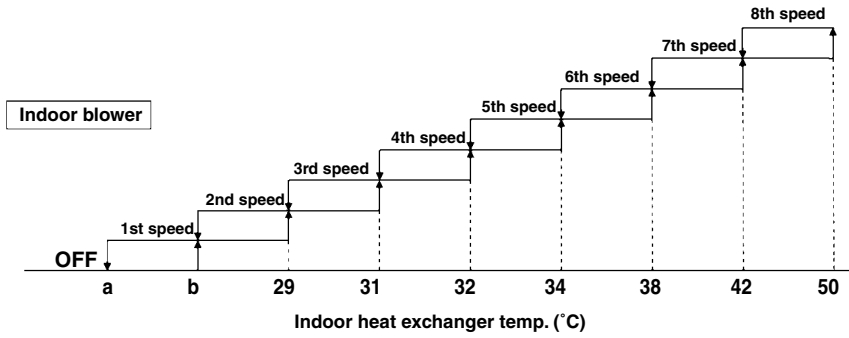

● Values of a, b

	a	b
At 0 Hz command	22	25
Other than 0 Hz command	17	19

Note (1) Refer to the table shown above right for the values a and b.

◆SRRM40 model

● Normal mode

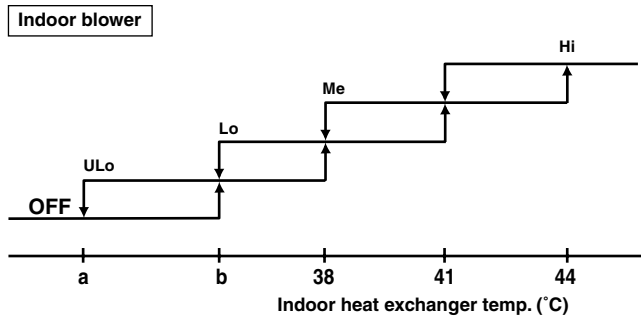

● Values of a, b

	a	b
At 0 Hz command	30	33
Other than 0 Hz command	17	30

Note (1) Refer to the table shown above right for the values a and b.

(f) Defrosting

(i) When the following conditions are met, the defrosting operation will start.

1) During normal operation

- a) When 30 minutes has passed since the start of heating or 30 minutes after the last defrosting (Cumulative actual operating time of compressor other than the outdoor unit frequency 0 Hz).
- b) When the outdoor heat exchanger thermistor temperature is -2°C or less for 3 continuous minutes after 27 minutes have passed.
- c) Outdoor thermistor temperature (Th6) – Outdoor gas piping thermistor temperature $\geq 0.44 \times$ Outdoor thermistor temperature + A $^{\circ}\text{C}$ or more. A value : Th6 $\geq -2^{\circ}\text{C} \cdot 4$, Th6 $< -2^{\circ}\text{C} \cdot 6$
- d) When the compressor is operating.
 - ▷ In addition, defrosting operation will start when the count of the decision frequency has become 0 Hz reaches 10 times or more and when all the conditions presented above in a), b) and d) are met.

2) During defrosting acceleration

- a) When 30 minutes has passed since the last defrosting (Cumulative actual operating time of compressor other than the outdoor unit frequency 0 Hz).
- b) When the compressor is operating.
 - ▷ In addition, defrosting operation will start when the count of the decision frequency has become 0 Hz reaches 10 times or more and when all the conditions presented above in a) and b) are met.

Note (1) Defrosting acceleration is when the finishing of the previous defrosting is according to the defrosting conditions of the 10 minutes that have passed.

3) Operation of function component in defrosting

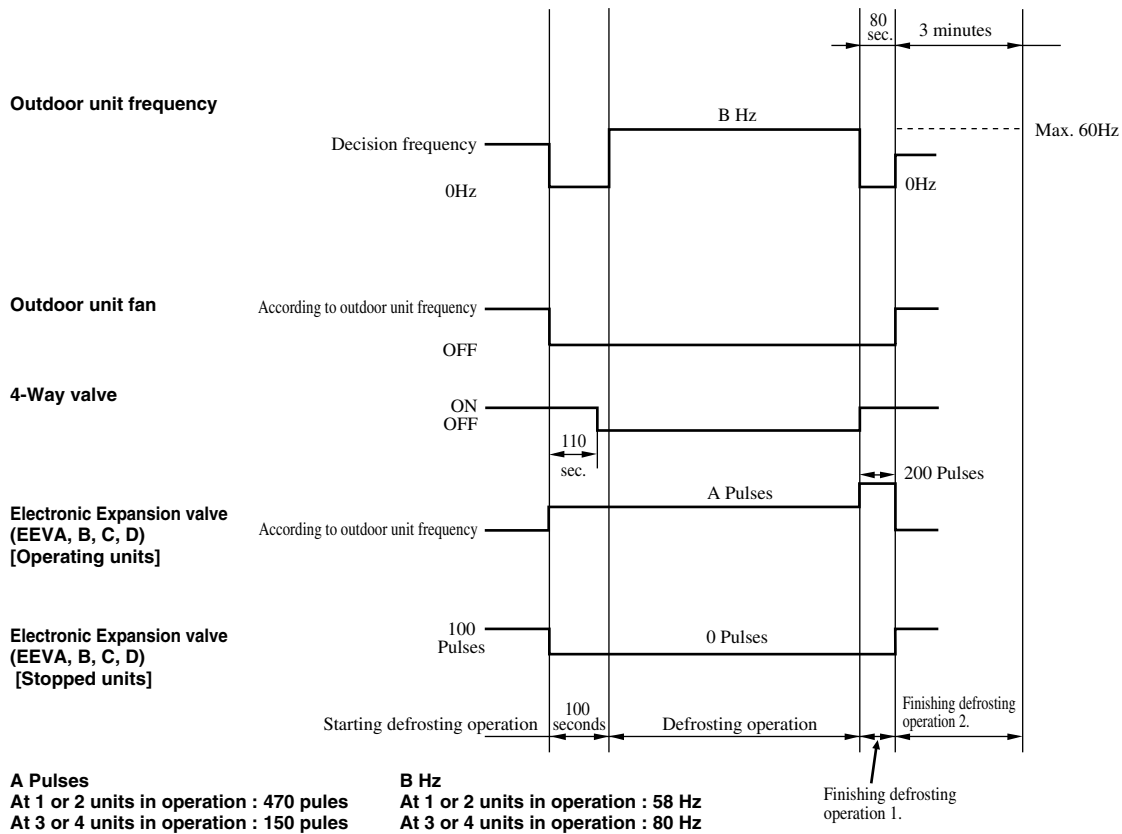

4) Conditions for finishing defrosting

When any of the following conditions is met, the defrosting finishing operation will start.

- ① When the outdoor heat exchanger thermistor temperature is 13°C or more for 70 seconds.
- ② When the outdoor heat exchanger thermistor temperature is 25°C or more.

(8) Determining the operating mode

The cooling and heating operating modes are the remote control switch mode that have been previously determined.

If a mode differing from these is selected after this, the selected mode will appear in the display of the remote control, but only the fan will operate.

Example	First operation			Second operation			Notes
	Selected Mode	Remote Control Display	Operation	Selected Mode	Remote Control Display	Operation	
1	Cooling	Cooling	Cooling	Heating	Heating	Fan (1)	• Different mode is only fan operation.
2	Cooling	Cooling	Cooling	Fan	Fan	Fan	
3	Heating	Heating	Heating	Cooling	Cooling	Fan	
4	Heating	Heating	Heating	Fan	Fan	Fan	

Note (1) If the display shows heating and the operation is fan, Hot Keep will operate.

Example of operating pattern

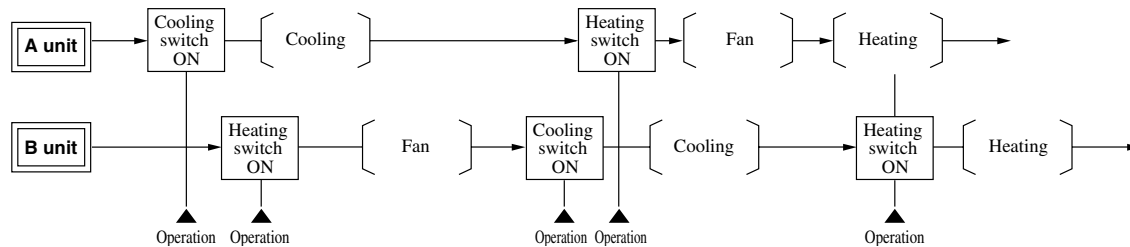

Note (1) [] indicates correct operation.

(9) Control and protection functions

(a) Control during start of compressor operation

1) Soft start

The inverter starts from 4 Hz when starting from the stop mode to control the starting current.

2) Start of protection for compressor

When the inverter decision frequency is 34 Hz or more, compressor protection starts.

- ① Start of protection I (When the unit is started after 6 hours or more have elapsed since the last compressor stop.)
After the compressor has been started, the frequency of the outdoor unit is maintained at a maximum of 60 Hz for 5 minutes, after which transition is made to the decision frequency.
- ② Start of protection II (Other than item ①)
After the compressor has been started, the frequency of the outdoor unit is maintained at 48 Hz for 1 minute and 45 seconds, after which transition is made to the decision frequency.
- ③ Start of protection III (The first time after the power is turned on and when starting when the total power-on time is less than 6 hours.)
After the compressor has been started, it is operated at 30 Hz for 1 minute. Then for the next 10 minutes it increases at a rate of 2 Hz every 30 seconds to the upper limit frequency of the outdoor unit. For the next 4 minutes, the increase is 2 Hz every 15 seconds.
- ④ The 4-way diverter valve protection (When the unit is started under the decision frequency of less than 34Hz). The unit is operated for 30 seconds under the outdoor unit's frequency of 34Hz and then it is operated in accordance with the decision frequency.

3) Delay of compressor start

If the compressor (inverter) is stopped by the operation of the cooling or heating thermostat, the operation switch on the remote controller or an abnormality, it cannot be restarted for 3 minutes.

However, turning on the power disables the 3-minute timer.

(b) Heating overload protection control

When the outdoor units are operating at a frequency other than 0 Hz and the outdoor air temperature is 12°C or more for 30 continuous seconds, the outdoor fan speed is reduced by one step to perform the current safe control. However, when one unit is operating, the outdoor frequency is forced to 30 Hz. Recovery is when the outdoor air temperature is 10°C or less.

(c) Cooling overload protection control

When the outdoor units are operating at a frequency other than 0 Hz and the outdoor air temperature is 39°C or more for 3 continuous minutes, the fan speed of the outdoor unit is increased 1 speed and the current safe control operates. Recovery is when the outdoor air temperature is 38°C or less.

(d) Low Hz continuous operation protection control

The following controls are performed to return the oil to the compressor when the outdoor frequency is less than 34 Hz and other than 0 Hz for 20 continuous minutes or more.

- 1) Forced operation at outdoor frequency of 34 Hz is performed for 1 minute.
- 2) The outdoor fan operates according to decision frequency and the expansion valve operates according to the outdoor frequency.
- 3) If the unit receives a command of that is higher than 34 Hz when operating at the forced 34 Hz, it will respond to the higher command and the operation of this control is ended.

(e) High Hz continuous operation protection control

The following controls are performed to protect the compressor when the outdoor frequency is 106 Hz or higher for 9 continuous minutes or more.

- 1) Forced operation at outdoor frequency of 104 Hz is performed for 1 minute.
- 2) The outdoor fan operates according to decision frequency and the expansion valve operates according to the outdoor frequency.
- 3) If the unit receives a command of that is lower than 104 Hz when operating at the forced 104 Hz, it will respond to the higher command and the operation of this control is ended.

(f) Heating low temperature protection control

The following controls are performed during heating operation when operating at an outdoor frequency other than 0 Hz and the temperature detected by the outdoor air temperature thermistor is 2°C or less for 1 continuous minute.

- 1) The fan speed of the outdoor unit is forced one speed higher.
- 2) When the outdoor air temperature thermistor reaches 4°C or more, the operation of this control is ended.

(g) Inching protection control

- 1) When the detected outdoor air temperature (detected by Tho-A) before the compressor stop is 22°C or less for the cooling operation and 0°C or less for the heating operation for 1 continuous minute, following control is executed in order to prevent the dilution of the refrigerant oil due to the dissolved refrigerant caused by the frequent start/stop of the compressor during the therm operation.

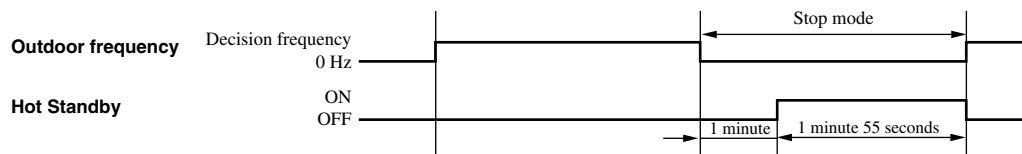

- 2) Restoration is made when the outdoor air temperature thermistor detects a temperature of 24°C or more during cooling or a temperature of 2°C or more during heating.

(h) Current safe control

- 1) When the converter input current detected by the current sensor (CT) exceeds the set value, the frequency is reduced by 2 Hz. Checks are performed every second following this and if the current still exceeds the setting, the frequency is reduced by another 2 Hz.
- 2) When the frequency is 30 Hz or less, this control will operate four in one hour and then perform an abnormal stop. At the same time, LED 5 on the printed circuit board for the outdoor unit will flash 3 times at 0.5 second intervals every 8 seconds. Note that on the first operation, the unit can be restarted after setting the compressor to stop mode.

(i) Current cut

An abnormal stop is made if the converter output current at the shunt resistor exceeds the set value. At the same time, LED 5 on the printed circuit board for the outdoor unit will flash 1 time at a 0.5 second interval every 8 seconds.

The unit is re-started after the stop mode, however, if the current cut has been operated 3 times at less than 30 Hz, the fourth start cannot be performed. (The timer lamp on the indoor unit will flash 1 time.)

(j) Outdoor unit abnormal stop and compressor motor protection

If the air conditioner is operating at an inverter frequency 30 Hz or more and an input current of 1 A or less is detected for 30 continuous seconds or more, a abnormal stop is performed. At the same time, LED 2 on the printed circuit board for the outdoor unit will flash 2 times at a 0.5 second interval every 8 seconds.

The unit is re-started after 3-minute's delay, however, if the re-start has been performed 4 times within 1 hour, the fifth start cannot be performed. (The timer lamp on the indoor unit will flash 2 times.)

(k) Discharge pipe thermistor interrupt protection

After 10 minutes from the compressor operation start other than 0 Hz of outdoor unit, when the temperature of discharge pipe thermistor detected the open circuit signal for 10 seconds (less than 7°C), the stop mode is performed immediately and then the unit is re-started.

(This is detected only once at the compressor ON condition.)

If abnormality occurred 4 times in succession, the abnormal stop is performed and the re-start is not performed. At the same time, the LED 2 on the printed circuit board of the outdoor unit will be lit for 4 seconds and lit off for 4 seconds.

(The timer lamp on the indoor unit flashes twice.)

(l) Power transistor overheat protection

If the thermal switch inside the power transistor is activated, the compressor is stopped immediately. While the unit can be restarted once temperature of the power transistor has gone down and/or after the 3-minute delay has finished, it cannot be started a third time if there is an abnormal stop of a restart within 1 hour. At the same time, LED 5 on the printed circuit board for the outdoor unit will flash 4 times at a 0.5 second interval every 8 seconds. (The timer lamp on the indoor unit will flash 4 times.)

Set value: 110 ± 10°C open / 90°C close

(m) Compressor overheat protection control

- 1) When the compressor thermo (51C) is OFF for 10 continuous seconds, the inverter is stopped. After that, when the compressor thermo (51C) becomes ON for 10 continuous seconds, the inverter is re-started.
- 2) When the discharge pipe thermistor temperature is 115°C for 5 continuous seconds, the inverter is stopped. If the temperature becomes 90°C after stop mode, the inverter is re-started.
- 3) If the inverter stop occurs 4 times within 1 hour, the abnormal stop is performed and the re-start is not performed. (The LED 5 on the printed circuit board of the outdoor unit will flash 5 times every 8 seconds at a 0.5 second's interval for 5 times. The timer lamp on the indoor unit will flash 5 times.)
- 4) When the detected temperature is 100°C, the following frequency control is performed.

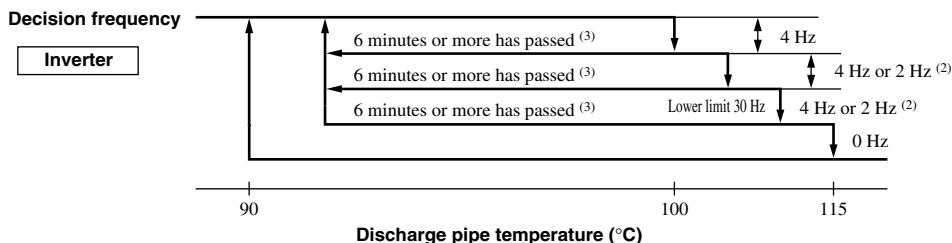

- Notes (1) If the discharge pipe temperature is 100°C, the frequency is lowered 4 Hz.
(2) After 40 seconds, if the discharge pipe temperature is lower than the previous temperature, the frequency is lowered 2 Hz; if it is higher, the frequency is lowered 4 Hz.
(3) If the discharge pipe temperature is 90°C or more and less than 100°C and the inverter frequency is maintained and/or the unit operates at the same frequency for 6 minutes or more, compressor overheat protection control is cancel and the unit returns to normal operation.

(n) Serial transmission abnormality protection

An abnormal stop is made if the outdoor unit does not receive serial signal commands, other than “Stop: 0 Hz,” from all the indoor controllers continuously for 1 minute and 55 seconds when the compressor is operating at an outdoor frequency of other than 0 Hz. At the same time, LED 5 on the printed circuit board for the outdoor unit will flash 6 times at a 0.5 second interval every 8 seconds. (The timer lamp on the indoor unit will flash 6 times.)



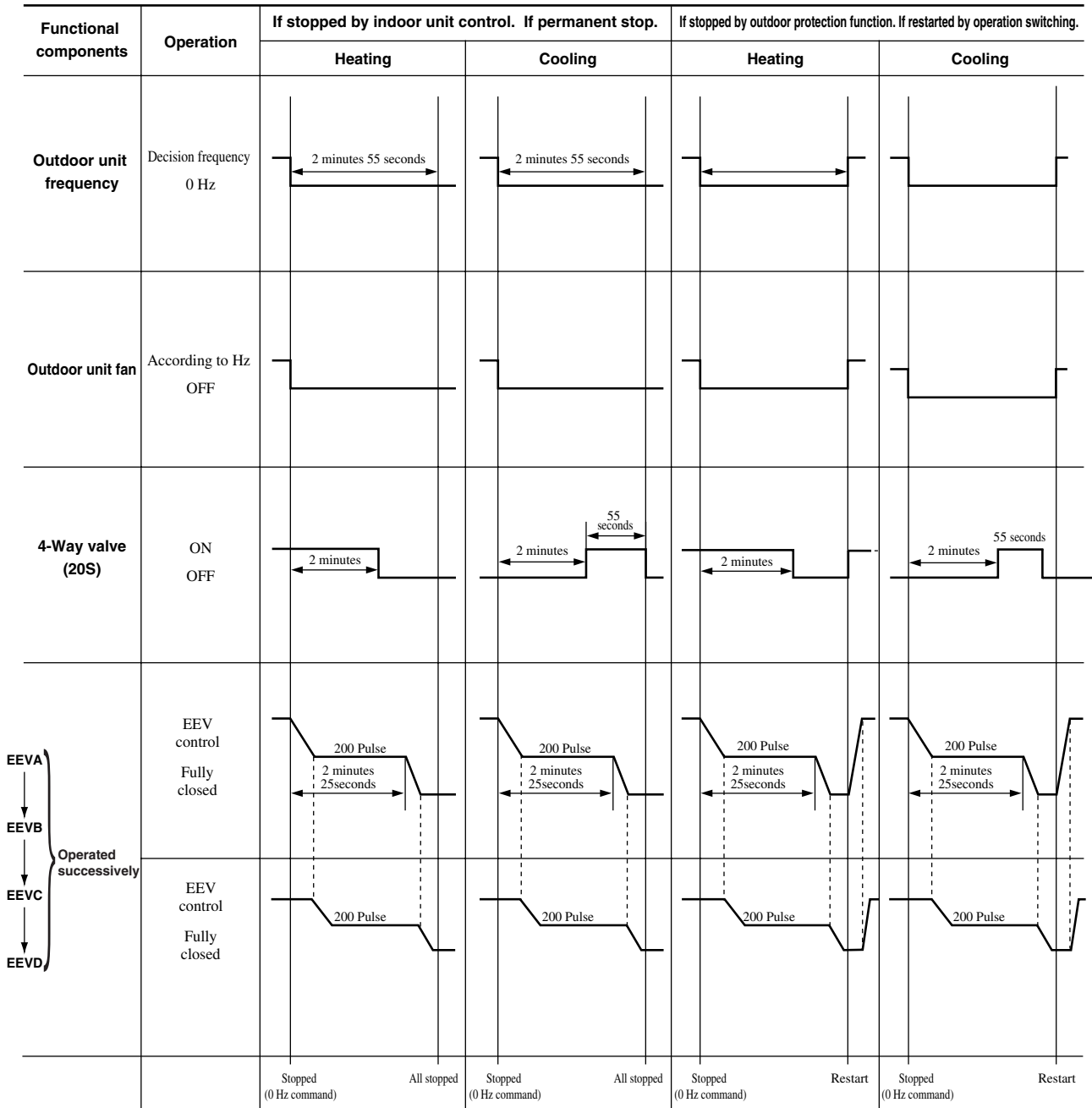

The unit can be restarted if serial signal is restored and/or the 3-minute delay has finished.

(o) Stop mode : When the decision frequency is 0 Hz; during switching mode, during protection function operation.



3.5 APPLICATION DATA



SAFETY PRECAUTIONS

- Please read these “Safety Precautions” first then accurately execute the installation work.
- Though the precautionary points indicated herein are divided under two headings,  **WARNING** and  **CAUTION**, those points which are related to the strong possibility of an installation done in error resulting in death or serious injury are listed in the  **WARNING** section. However, there is also a possibility of serious consequences in relationship to the points listed in the  **CAUTION** section as well. In either case, important safety related information is indicated, so by all means, properly observe all that is mentioned.
- After completing the installation, along with confirming that no abnormalities were seen from the operation tests, please explain operating methods as well as maintenance methods to the user (customer) of this equipment, based on the owner’s manual. Moreover, ask the customer to keep this sheet together with the owner’s manual.

WARNING

- This system should be applied to places as households, residences and the like. Application to inferior environment such as engineering shop could cause equipment malfunction.
- Please entrust installation to either the company which sold you the equipment or to a professional contractor. Defects from improper installations can be the cause of water leakage, electric shocks and fires.
- Execute the installation accurately, based on following the installation manual. Again, improper installations can result in water leakage, electric shocks and fires.
- For installation, confirm that the installation site can sufficiently support heavy weight. When strength is insufficient, injury can result from a falling of the unit.
- For electrical work, please see that a licensed electrician executes the work while following the safety standards related to electrical equipment, and local regulations as well as the installation instructions, and that only exclusive use circuits are used.
Insufficient power source circuit capacity and defective installment execution can be the cause of electric shocks and fires.
- Accurately connect wiring using the proper cable, and insure that the external force of the cable is not conducted to the terminal connection part, through properly securing it improper connection or securing can result in heat generation or fire.
- Take care that wiring does not rise upward, and accurately install the lid/service panel. It’s improper installation can also result in heat generation or fire.
- When setting up or moving the location of the air conditioner, do not mix air etc. or anything other than the designated refrigerant (R22) within the refrigeration cycle.
Rupture and injury caused by abnormal high pressure can result from such mixing.
- Always use accessory parts and authorized parts for installation construction. Using parts not authorized by this company can result in water leakage, electric shock, fire and refrigerant leakage.
- Ventilate the work area when refrigerant leaks during the operation. 
Coming in contact with fire, refrigerant could generate toxic gas.
- Confirm after the foundation construction work that refrigerant does not leak.
If coming in contact with fire of a fan heater, a stove or movable cooking stove, etc., refrigerant leaking in the room could generate toxic gas.

CAUTION

- Execute proper grounding. Do not connect the ground wire to a gas pipe, water pipe, lightning rod or a telephone ground wire. 
Improper placement of ground wires can result in electric shock.
- The installation of an earth leakage breaker is necessary depending on the established location of the unit. No installing an earth leakage breaker may result in electric shock.
- Do not install the unit where there is a concern about leakage of combustible gas. 
The rare event of leaked gas collecting around the unit could result in an outbreak of fire.
- For the drain pipe, follow the installation manual to insure that it allows proper drainage and thermally insulate it to prevent condensation. Inadequate plumbing can result in water leakage and water damage to interior items.

3.5.1 Installation of indoor unit

(1) Wall mounted type (SKM)

(a) Caution for installation

- 1) The system should be applied to places as households, residences and the like.
- 2) The equipment shall be installed in accordance with national wiring regulations.
- 3) The connection to the fixed wiring of the mains supply must be made via a double pole isolating switch with a contact gap of at least 3mm in each pole.
- 4) When the outdoor unit has a possibility of being overturned or being displaced and fall from its original installation position, the outdoor unit should be fixed in its position by the use of anchor bolts or wires.

(b) Installation of indoor unit

1) Fixing of installation Board

- Find the inside wall structures (pillar, etc.) and secure the board after checking the horizontal level.

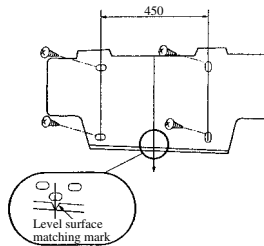

- Horizontal level adjustment of the board is conducted with four temporarily tightened screws.

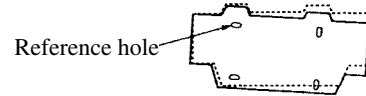

- Adjust so that the board will be horizontal with the reference hole in the center.

**Installation Space (Indoor Unit)
Models SKM22, 25 models**

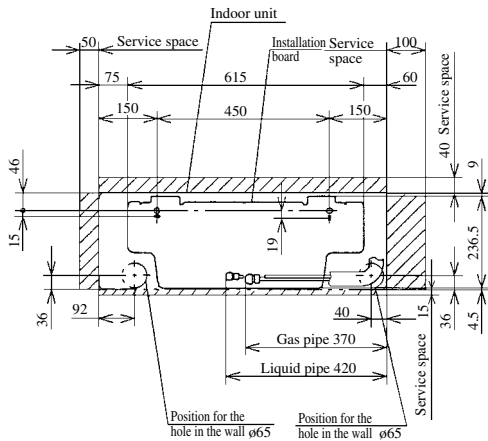

Models SKM28, 32, 40 models

Unit: mm

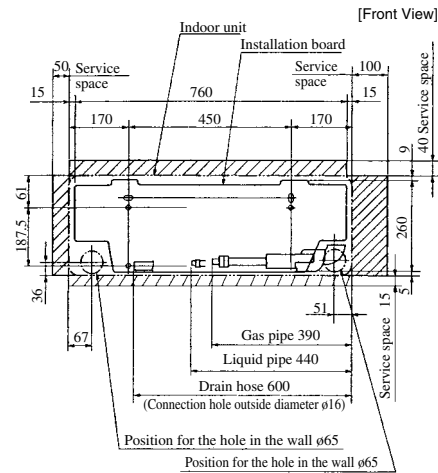

Model SKM50 model

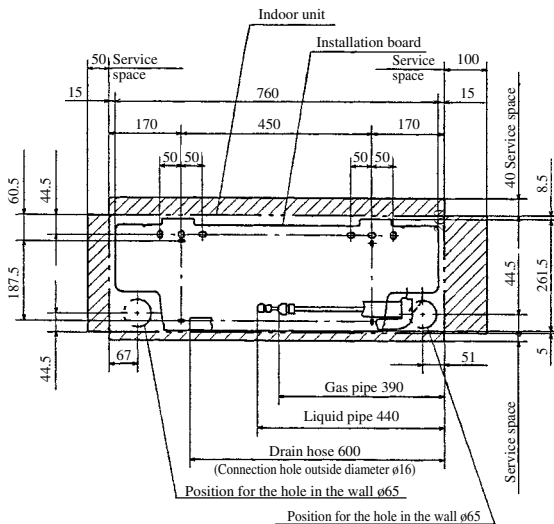

2) Drilling of holes in the wall and fixture of sleeve

- The connecting wires may touch the metal inside the wall and cause danger so it is necessary to always use the sleeve.

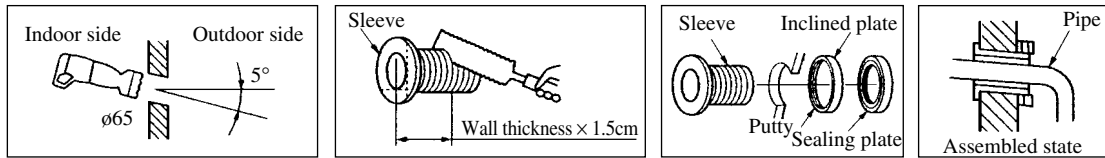

- Drill a hole with a 65 whole core drill.
- When the pipe is connected at the rear, cut off the lower and the right side portions of the sleeve collar (as shown by the broken line.)

3) Mounting of interconnecting wires (Field wiring)

◆ SKM22, 25, 28, 32, 40 models.

- Remove the lid.
- Remove the terminal block cover.
- Connect the connection wire securely to the terminal block.
 - Connect the connection wire securely to the terminal block. If the wire is not affixed completely, contact will be poor, and it is dangerous as the terminal block may heat up and catch fire.
 - Take care not to confuse the terminal numbers for indoor and outdoor connections.
 - Affix the connection wire using the wiring clamp.
- Attach the terminal block cover.
- Attach the lid.

◆ SKM50 model

- Open the suction grille, then remove the lid.
- Remove the wiring clamp.
- Pass the connecting wire to terminal block from behind of indoor unit.
 - Connect the connection wire securely to the terminal block. If the wire is not affixed completely, contact will be poor, and it is dangerous as the terminal block may heat up and catch fire.
 - Take care not to confuse the terminal numbers for indoor and outdoor connections.
 - Affix the connection wire using the wiring clamp.
- Fix the connecting wire by wiring clamp.
- Attach the lid.
- Close the suction grille.

Use cables for interconnection wiring to avoid loosening of the wires.
 CENELEC code for cables Required field cables.
 H05 RNR4G1.5 (Example)
 H Harmonized cable type
 05 300/500 volts
 R Natural-and/or synth. rubber wire insulation
 N Polychloroprene rubber conductors insulation
 R Stranded core
 4 Number of conductors
 G One conductor of the cable is the earth conductor (yellow/green)
 1.5 Section of copper wire (mm²)

• SKM22, 25, 28, 32, 40 models.

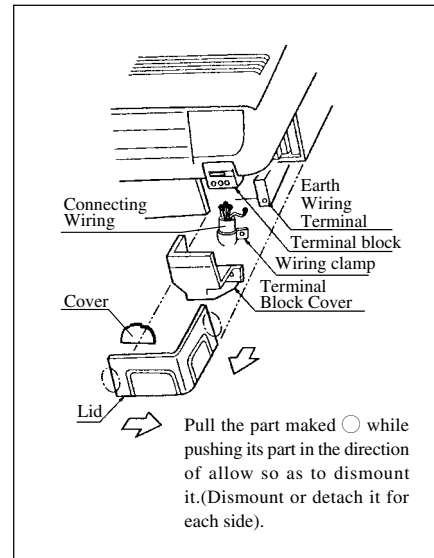

• SKM50 model

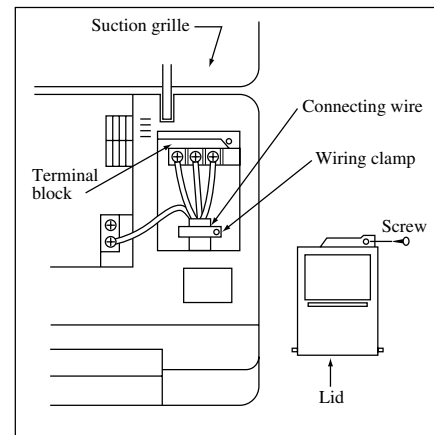

4) Shaping the pipe and drain hose

[Shaping the pipe]

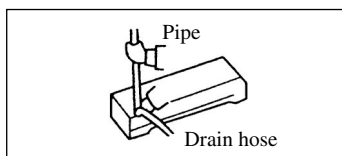

- Hold the bottom of the pipe and change its direction before stretching it and shaping it.

[Taping of the exterior]

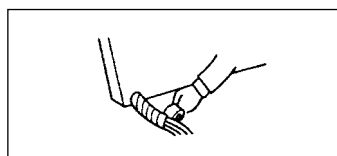

- Tape only the portion that runs through the wall. Always tape the crossover wires with the pipe.

Cautions when piping from the left and the rear center of the unit

[Top View]

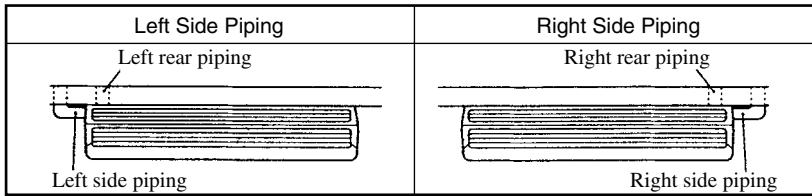

The piping can be removed from the rear, left, left rear, right and from under the unit.

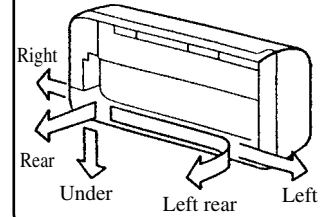

[Procedure for exchanging the drain hose.]

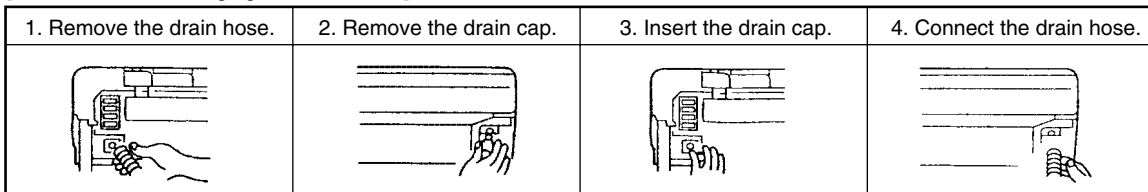

- Loosen and remove the spring-type clamp.
- Remove with your hand or a pair of pliers.
- Use a hexagonal wrench to correctly insert the drain cap which was removed in 2. Caution: Be careful because if the cap is not inserted properly, water leak may occur.
- Loosen the spring-type clamp and securely insert the drain hose. Caution: Be careful because if the cap is not inserted properly, water leak may occur.
- When conducting the central rear piping, use a nipper to cut out knock-out holes in the installation board.

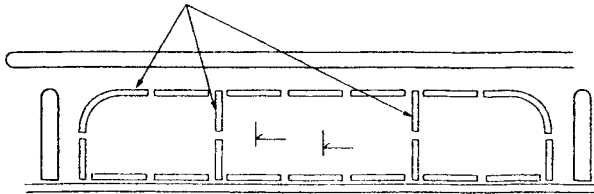

- Do not place the power supply cords above the gutter, because the air conditioner is structured in a way where condensation on the back side is collected in to the drain pan before drainage.

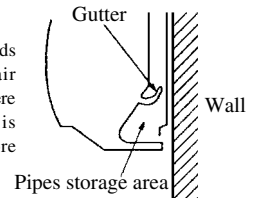

Drainage

- The drain hose must be fit with a downward slope.
- Do not set the drain hose like the following illustrations.

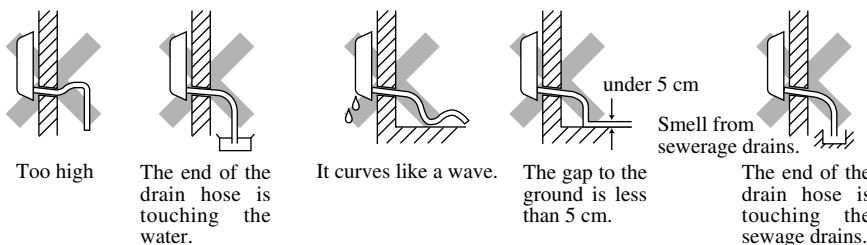

- Pour water in the drain pan below the heat exchanger and confirm that the water is drained outside.
- If the extension drain hose is indoors, make sure it is insulated using a shielding pipe (not supplied).

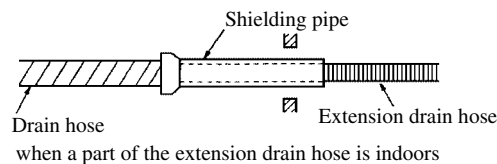

5) Securing the Indoor Unit to the Installation Board

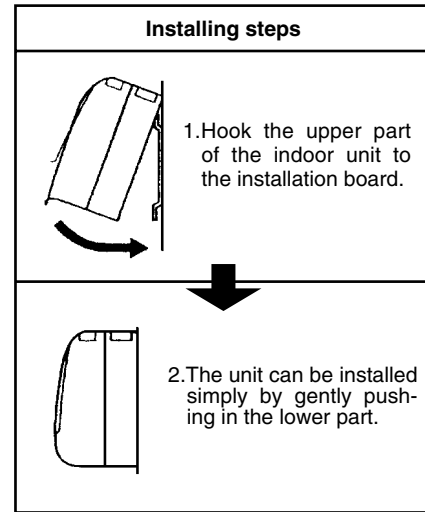
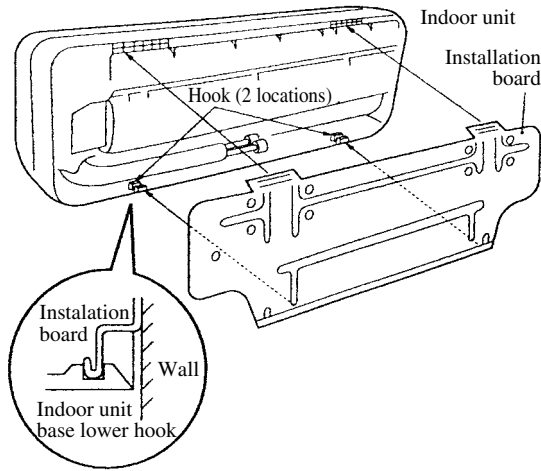

(2) Ceiling recessed type (SRRM)

These instructions are for the installation of the main unit. If this unit is to be used in combination with a separately sold component, also refer to the installation procedures for that component. (See page 98.)

(a) Caution for installation

The safety precautions for installation are the same as the SKM type. Please refer to page 87.

(b) Installation of indoor unit

1) Installation dimensions

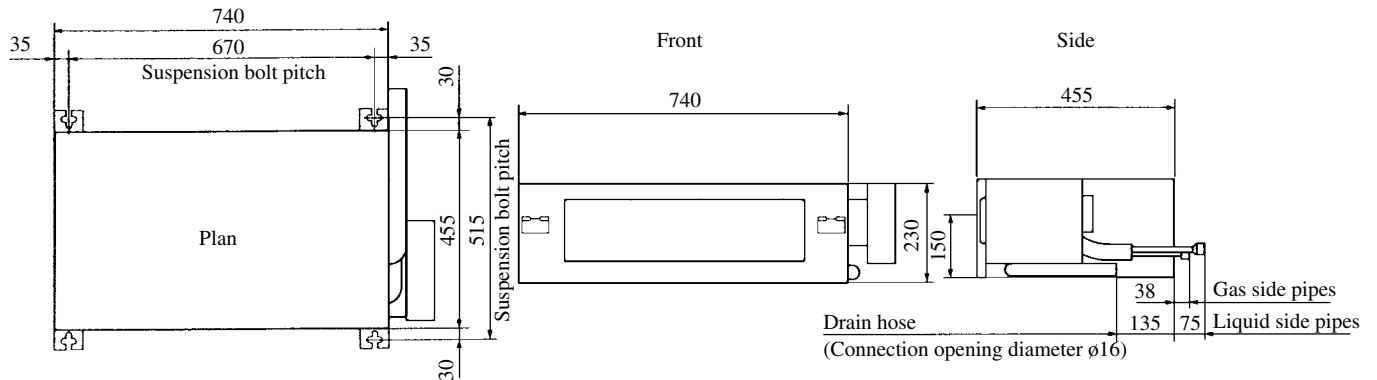

2) Drilling of holes in the wall and fixture of sleeve

The instructions for installation is the same as the SKM type. Please refer to page 88 .

3) Securing the ceiling suspension bolts

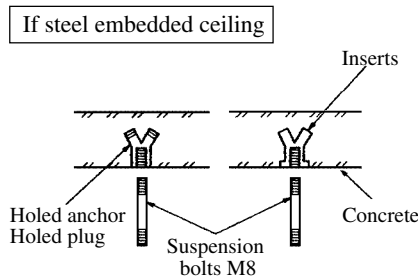

If wooden ceiling

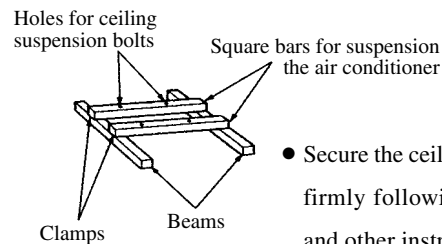

- Secure the ceiling suspension bolts firmly following the illustrations and other instructions.

4) Installing the main unit

- Attach the washers and nuts to the ceiling suspension bolts.
- Attach the suspension tool to the above nuts, and tighten the nuts.

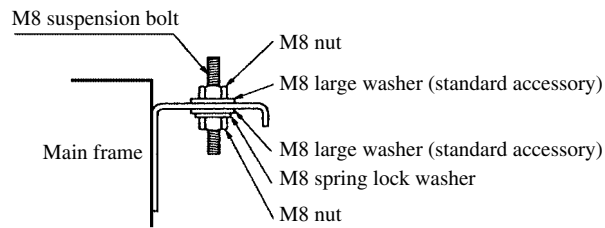

- If it is not leveled, the float switch may malfunction or may not start.

5) Connecting the drain pipes

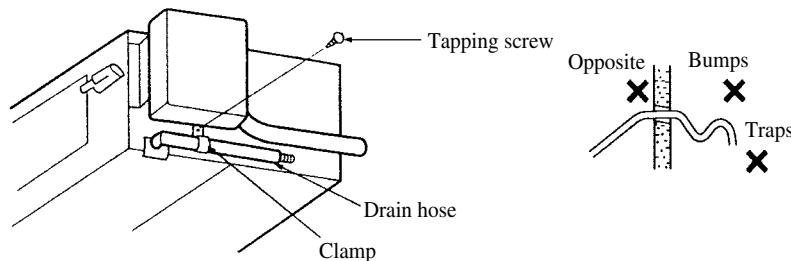

Note (1) Conduct the installation correctly, and ensure that the water is draining correctly. It may lead to water leaks.

- Insert the drain hose as far as possible through the lower section of the side of the unit, and secure it with clamps.
- The drain pipes should be set in a downward slope (over 1/100), and it should not have any bumps or traps along its route.
- The indoor drain pipes must be insulated.

6) Securing the wireless receiver

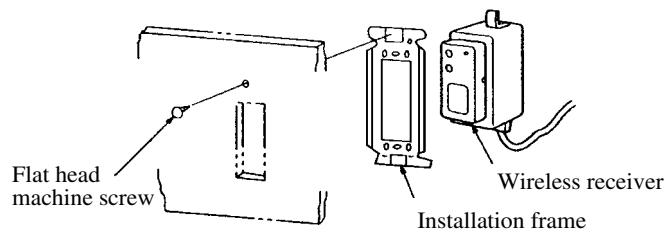

- With a (-) screwdriver, secure the installation frame to the grooves on either sides of the wireless receiver.
- Refer to the installation Instructions for each separately sold part, regarding the installing location of the wireless receiver.

3.5.2 Installation of remote controller

(1) Mounting method of battery

Uncover the remote control switch, and mount the batteries (UM-4 × 2 pieces) in the body regularly.

(Fit the poles with the indication marks, ⊕ & ⊖ without fail)

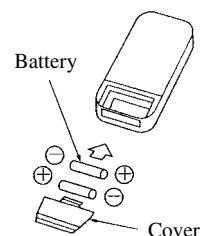

(2) Fixing to pillar or wall

- Conventionally, operate the remote control switch by holding in your hand.
- In the case of stationary operation service as by mounting on the holder for the remote control switch, make sure that the locating place is satisfactory for access service before installing it.
- Avoid installing it on a clay wall etc.

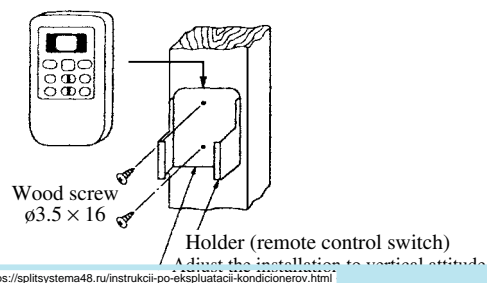

3.5.3 Installation of outdoor unit

(1) Selection of installation location

(Please install with the customer's consent in a location that follows the conditions listed below.)

- Where the following installation space is available, and where air does not gather.
- Where rain and sunlight do not directly hit the unit, and where there is enough air circulation.
- Also, where the unit cannot be buried by snow.
A location which can sustain the weight of the unit, and where noises and vibrations are not enhanced.
- Where blasts of cold or hot air and noise do not bother the neighbors.
- Where the unit does not receive heat radiation from other heat sources.
- Where there are no obstructions (animals, plants, etc.) to the suction inlet and blowing outlet.
- Where water may drain out.
- Please avoid the following locations.

- Where there is constant exposure to harsh winds such as the top floors of a building. Also, locations with exposure to salty air.
- Where there are oil splashes, vapor, and smoke.
- Where there are possibilities of flammable gas leaks.

(i) Installation space (on a flat surface)

If there are no open space to install the unit, and it must be installed in a location where there are obstructions such as a wall to the suction inlet and the blowing outlet, please observe the following points. In such cases, please also be aware that the performance of the cooling/heating system may decline by approximately 10%.

Unit: mm

Symbol	L1	L2	L3	L4
Example				
I	Open	300	100	200
II	Open	50	150	200
III	500	Open	100	200

Notes (1) A square wall is not permissible. If the wall is taller than 2m, or if there is extra wall space over the unit, please allow more space than listed in the above table.

(2) When installing multiple units, please ensure enough space for air inlet to avoid any short-circuits.

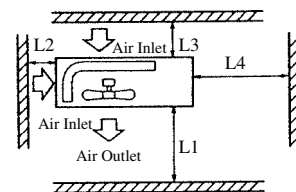

(j) Installation method at a location with strong winds

- Please install with the blowing outlet facing the wall.
- Please install so the direction of the air from the blowing outlet will be perpendicular to the direction of the wind.
- Please secure the unit with wires or fall prevention tools if the foundation is unstable.

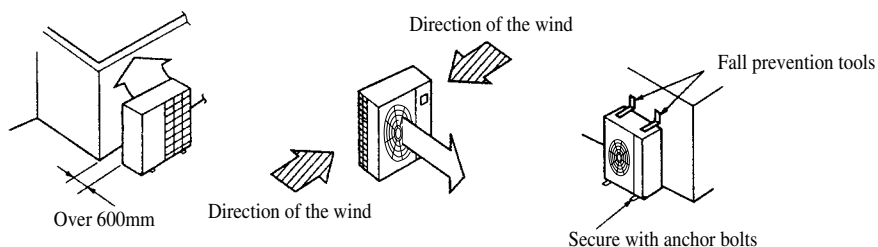

(2) Moving / Installation of Unit

- Move the unit as close to the installation location as possible in its packed form.
- If it must be unpacked before moving, use a nylon sling, or apply a board to protect the unit from any damages and lift it with a rope.
- Install the indoor unit so it will be horizontal, or so there will be a slight downward slope towards the drainage hole.
- Also, secure the legs of the unit to a firm foundation to prevent any instabilities.
- If there is a possibility of vibrations transferring to the house, apply a vibration prevention rubber (available in stores) between the unit and the installation board and secure the unit.
- To ensure correct connections, mark each ends of the cables and the pipes with letters, A, B, C and D. It is important to use the same letter for the corresponding cables and pipes.

Securing the Unit

- Locations to secure the bolts.

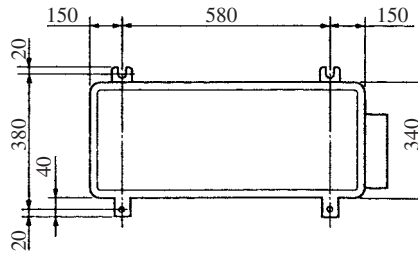

Unit: mm

- Use M10-M12 for the retaining bolts.
- Secure it firmly so the unit will not fall during earthquakes and from sudden gusts of wind.

Drainage

- There are 3 holes in the bottom panel of the outdoor unit to drain condensation.

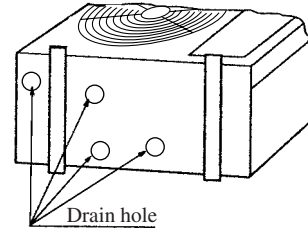

Removing the Outer Panel

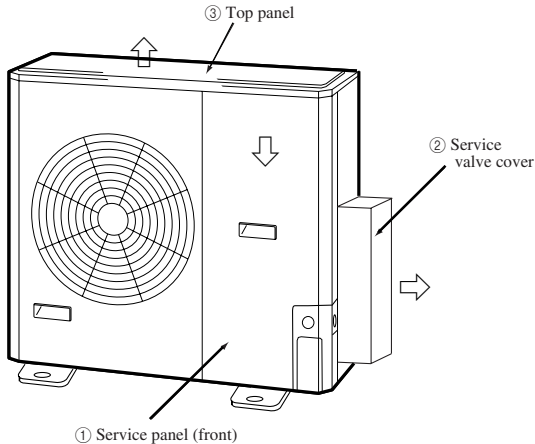

① Service panel (front)

- Remove when conducting the following: measuring the high/low pressure during maintenance, depressurizing, charging the refrigerant, operating the protective function.
- Remove the screws, and pull the panel towards the direction of the arrow.

② Service valve cover

- Remove the screws, and pull the cover towards the direction of the panel.

③ Top panel

- Remove the screws, and pull the panel towards the direction of the arrow.

3.5.4 Setup of volt select sw

Setup VOLT SELECT SW on control board as follows.

- ① In 240V area, put SW8 to ON.
- ② In 220/230V area, put SW8 to OFF.

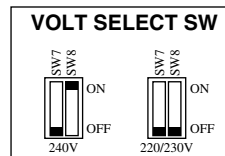

3.5.5 Electric wiring

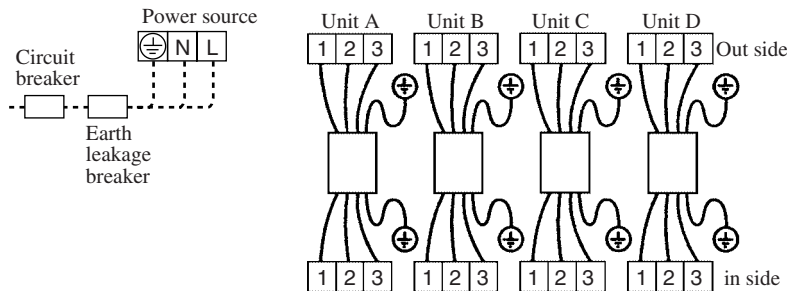

(1) Connection of the power lines

- This multi-type room air conditioner receives its power from outside.
- An earth leakage breaker and a circuit breaker must be installed.

Their capacities are listed below.

- (d) Use the power supply wires specified below. Different wires may cause heat generation and fire. Do not to use unspecified wires.

Never bundle, wind or treat the power wires. Otherwise, heat or fire may be generated.

SCM80ZA	30A
---------	-----

Use cables for interconnection wiring to avoid loosening of the wires.

CENELEC code for cables Required field cables.

H05 RNR3G4.0 (Example)

H Harmonized cable type

05 300/500 volts

R Natural-and/or synth. rubber wire insulation

N Polychloroprene rubber conductors insulation

R Stranded core

3 Number of conductors

G One conductor of the cable is the earth conductor (yellow/green)

4.0 Section of copper wire (mm²)

[POWER SUPPLY CODE]

CENELEC code for cables required field cables.

H05RNR3G 4.0

- (e) After connecting the power supply wires, make sure to secure the wires with wiring clamps.

(2) Connecting the outside/inside crossover wires

- (a) Ensure that crossover wiring is matched with crossover piping in A,B and C rooms.

- (b) The length of the crossover wires should be under 25 m. If it longer than 25 m, signal errors between the units may occur and cause the operation to shut down.

- (c) Use the crossover wires specified below. Different wires may cause heat generation and fire. Do not to use unspecified wires.

[INTERCONNECTING WIRING CODE]

CENELEC code for cables required field cables.

H05RNR4G 1.5

- (d) Make sure the terminal numbers on the terminal board of the indoor and outdoor connections are correct.

- (e) After connecting the crossover wires to the terminal board, use wiring clamps to secure the wiring.

3.5.6 Refrigerant Piping

(1) Limit

The maximum permissible length of the refrigerant pipes for the outdoor units, and the maximum permissible height difference for the outdoor units are as shown below.

		SCM80ZA
Length for one indoor unit		under 25m
Total length for all rooms		under 60m
Height difference	Lower installation spot of the indoor unit A	under 15m
	Upper installation spot of the indoor unit B	under 10m
	Maximum height difference of the indoor units C	under 25m
Length of chargeless refrigerant pipe*		40m

- * If the total length for all the rooms exceeds the length of chargeless refrigerant pipe, additionally charge with refrigerant according the item 4.

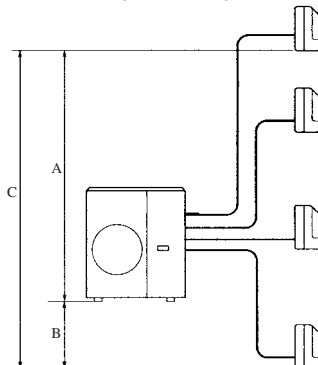

• The diameter of the refrigerant pipe:

Class of indoor unit (kW)		2.2 · 2.5 · 2.8kW	3.2 · 4.0 · 5.0kW
Diameter of joint pipe	Liquid side	ø 6.35 · t 0.8	
	Gas side	ø 9.52 · t 0.8	ø 12.7 · t 0.8

• Outdoor unit and the total connectable indoor units (class kW):

Model	Total of indoor units (class kW)
SCM80ZA	12.0kW

(2) Connection of refrigerant piping

- The service valve corresponding to each indoor unit is as illustrated in the right figure.
- Regarding the change in the sizes of gas side pipes (usage of the variable joints); if a 3.2/4.0/5.0 kW class indoor unit (gas side pipe 12.7) is going to be connected to the rooms A and C service valves (9.52), or if a 2.2-2.8 kW class indoor unit (gas side pipe 9.52) is going to be connected to the rooms B and D service valves (12.7), variable joints (1, 2) available as accessories must be applied to the gas side service valves.

[Examples of use of variable diameter joints]

Connection of indoor unit of Class 3.2 to A unit.

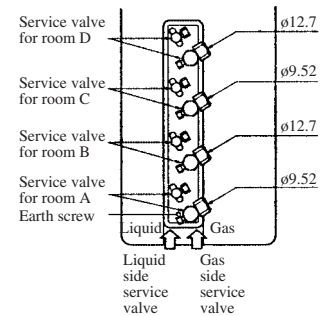
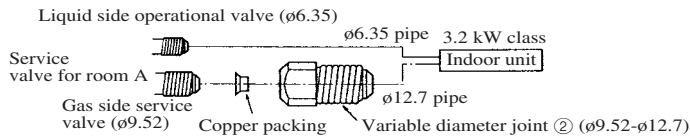

- Securely fit the copper packing between the service valve and the variable diameter joint to prevent shifting.
- Cover the pipes with tape so that dust and sand do not enter the pipe until they are connected.

[Connection of pipes]

- When connecting the pipes to the outdoor unit, be careful about the discharge of fluorocarbon gas or oil.
- Make sure to match the pipes between the indoor unit and the outdoor unit with the correct service valves.

(1) Preparations

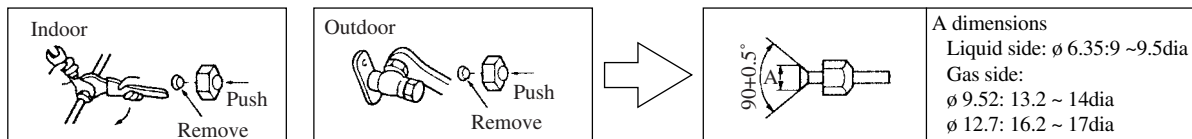

- Remove the flare nut (from both liquid and gas sides).
- Remove the flare nut (from both liquid and gas sides).
- Fit the removed flare nut to the joint pipe, and then flare it.

(2) Connection

Indoor

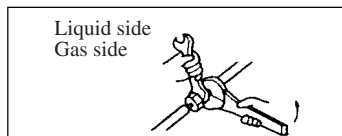

- Secure the nut with a specified tightening torque to avoid any gas leaks.

Outdoor

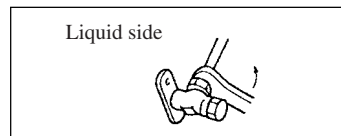

- Secure the nut with a specified tightening torque to avoid any gas leaks.

Gas side

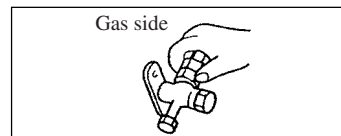

- When air purging with a vacuum pump, secure the nut with a specified tightening torque to avoid any gas leaks.
- When air purging with a refrigerant from an outdoor unit, just temporarily secure the nut.

- Specified tightening torques are as follows:

Liquid side (ø 6.35): 17mm in width across flat of the flare nut: 15.7-19.6 N·m (1.6-2.0 kgf·m)

Gas side (ø 9.52): 22mm in width across flat of the flare nut: 29.4-39.2 N·m (3.0-4.0 kgf·m)

Gas side (ø 12.7): 24mm in width across flat of the flare nut: 39.2-49.0 N·m (4.0-5.0 kgf·m)

(3) Air purging

To protect the global environment, use a vacuum pump that do not release flourocarbon gas into the atmosphere.

Note: Fully open the service valves (on both liquid and gas sides) after completing air purging

- Remove the cap on both gas and liquid sides before starting operation.
- After completing the operation, do not forget to tighten the cap (gas may leak).
- Conduct air purging for all connected indoor units.

Procedure

- ① Secure all flare nuts on both indoor and outdoor sides to prevent leaks from the pipes.
- ② Connect the service valves, charge hose, manifold valve and vacuum pump as shown in the right figure.
- ③ Fully open the handle Lo for the manifold valve, and pump a vacuum for 15 minutes. Ensure that the meter is indicating -0.1 MPa (-76cmHg).
- ④ After vacuuming, fully open the operational valve (both liquid and gas sides) with a hexagon wrench.
- ⑤ Ensure that there are no gas leaks from the joints in the indoor and outdoor units.
- ⑥ Repeat the above steps ① ~ ⑤ for all connected indoor units.

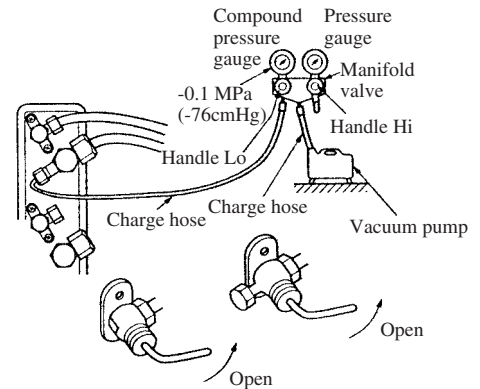

(4) Additional refrigerant charge

- (a) When the total refrigerant pipe length for all the rooms exceeds the length of the uncharged pipe (40m), additional refrigerant is required.
(If 40m or less, additional charge is not required.)
- (b) For this multi type room air conditioner, it is not necessary to charge the refrigerant for the total maximum length in all the rooms.

Model	Charged pipe length (Amount of uncharged refrigerant) *1	On site additional charge	Maximum total pipe length for all rooms (Maximum amount of refrigerant) *2
SCM80ZA	40m (2600g)	20g/m	60m (3000g)

*1: Charge amount at the time of shipment.

*2: Maximum charge amount of the refrigerant (additional charge of 400g on site).

- (c) Ensure that there are no gas leaks from the pipe joints by using a leak detector or soap water.

(5) Heat insulation for joint

Heat insulation for joints

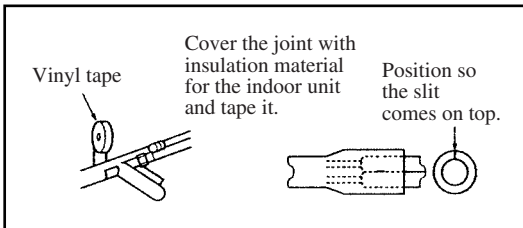

Finish and fixing

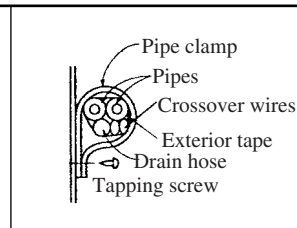

Apply exterior tape and shape along the place where the pipes will be routed. Secure to the wall with a pipe clamp. Be careful not to damage the pipes and the wires.

3.5.7 Test run and handling instruction

(1) Inspection

Check according to the following check items.

(2) Test run

- (1) Conduct the test run after turning on the power for 20 minutes.
(Run electricity for 20 minutes with a hot stand-by to prevent compression of the compressor liquid.)
- (2) If the compressor does not operate after the operation has started, wait for 5 ~ 10 minutes.
(This may be due to a delayed start.)
- (3) Carry out the test run for each unit individually. (If 2 or 3 units are tested at the same time, wrong wiring and wrong pipe connections cannot be checked.)
- (4) After each individual test, run the units in all the rooms simultaneously and check the units.
- (5) Test both the cooler and the heater.

(Three-minute restart preventive timer)

When the air conditioner is restarted or when changing the operation, the unit will not start operating for approximately 3 minutes. This is to protect the unit and it is not a malfunction.

Installation test check points

Check the following points again after completion of the installation, and before turning on the power. Conduct a test run again and ensure that the unit operates properly. At the same time, explain to the customer how to use the unit and how to take care of the unit following the instruction manual.

After installation

- The power supply voltage is correct as the rating.
- No gas leaks from the joints of the service valve.
- Power cables and crossover wires are securely inserted and fixed to the terminal board.
- Each indoor and outdoor unit is properly connected (no wrong wiring or piping).
- Service valve is fully open.
- Refrigerant has been additionally charged (when the total pipe length exceeds the refrigerant charged pipe length).
- The pipe joints for indoor and outdoor pipes have been insulated.
- Earthing work has been conducted properly.

Test run

- Air conditioning and heating are normal.
- No abnormal noise.
- Water drains smoothly.
- Protective functions are not working.
- Operation of the unit has been explained to the customer.

Beware of wrong connections in refrigerant piping and wiring

- Make sure to match the piping and wiring from each unit to the outdoor unit.
- Be careful because if connections are wrong, normal operation cannot be achieved and may damage the compressor.

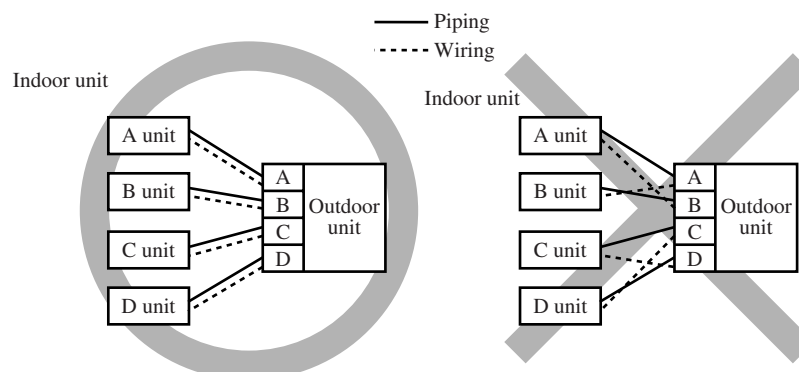

[Correct connections]

[Example of wrong connections]

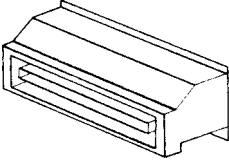
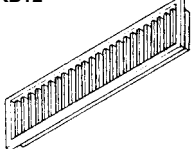
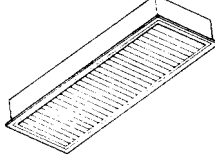
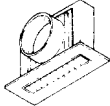

3.5.8 Installation of optional parts (Ceiling recessed type)

■ Table of optional parts

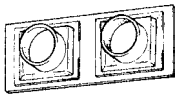
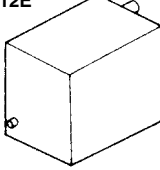
<p>① Air outlet duct RFD12</p> 	<p>② Air outlet grille for suspended ceiling RKB12</p> 	<p>③ Bottom air inlet grille set RTS12</p> 	<p>④ Air outlet unit for ceiling (1 opening) RTB12</p> 
<p>⑤ Flexible duct $\phi 150$ S97684 (4 m) • S98223 (3 m) S97683 (2 m) • S97682 (1 m)</p> 	<p>⑥ Duct joint for air outlet plate RFJ22</p> 	<p>⑦ Drain up kit RDU12E</p> 	

■ Examples of Installation

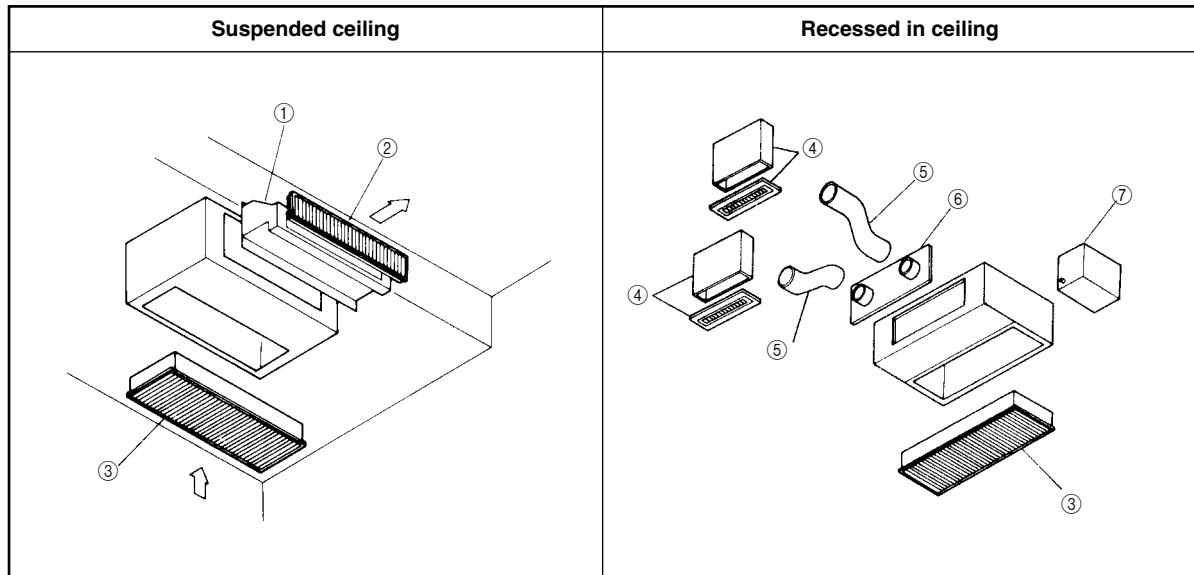

(1) Air outlet duct

(a) Part number: RFD12

The air outlet duct is used to mount to a unit when using the air outlet grille for suspended ceiling (RKB12).

(b) Parts list

Name	Qty.
Air outlet duct	1
Connecting wire for louver motor	1
Clamp	1
Tapping screw ($\phi 4 \times 10$)	1
Tapping screw ($\phi 4 \times 16$)	8

(c) Installation

The following is the procedure for installing the air outlet grille for suspended ceiling (RKB12).

(d) Installation procedure

- 1) Mount the air outlet duct to the indoor unit using the eight tapping screws.
- 2) Remove the motor cover on the right side of the air outlet duct, connect the connecting wire for louver motor and secure with clamp.
- 3) Connect one end of the connecting wire for louver motor to the connector for the louver motor inside the controller and use the clamp inside the controller to secure it.
- 4) Clamp the connecting wire for louver motor and the wire for wireless receiver provided with the indoor unit to the positions on the indoor unit shown at the right and secure with clamp.

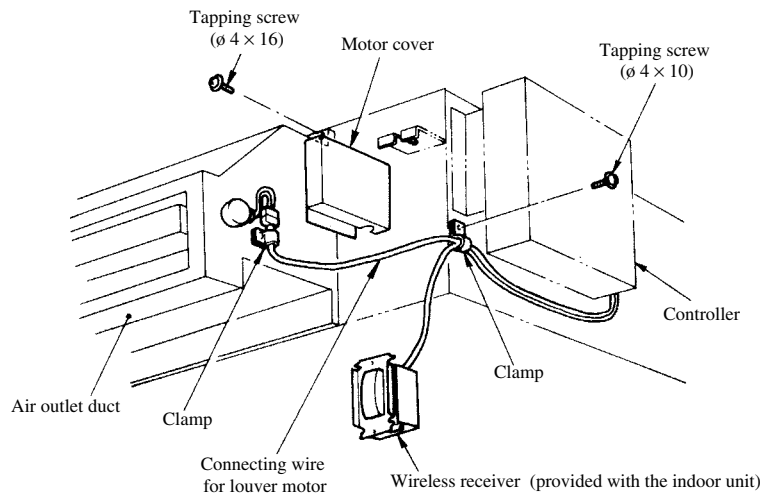

Notes

- When receiver unit is mounted to wall

► Exterior drawing

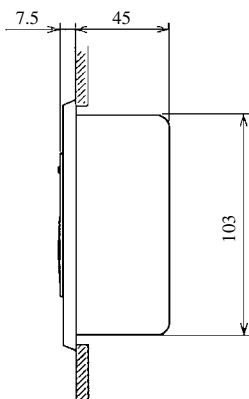
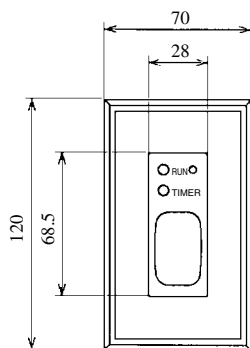

Cross-section

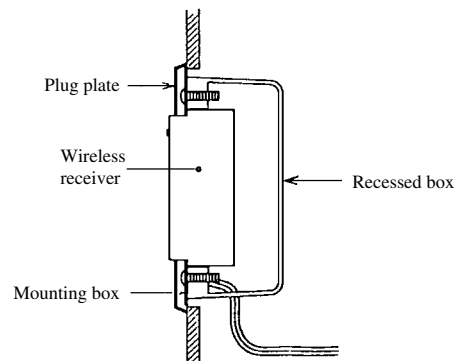

Unit: mm

► Mounting drawing

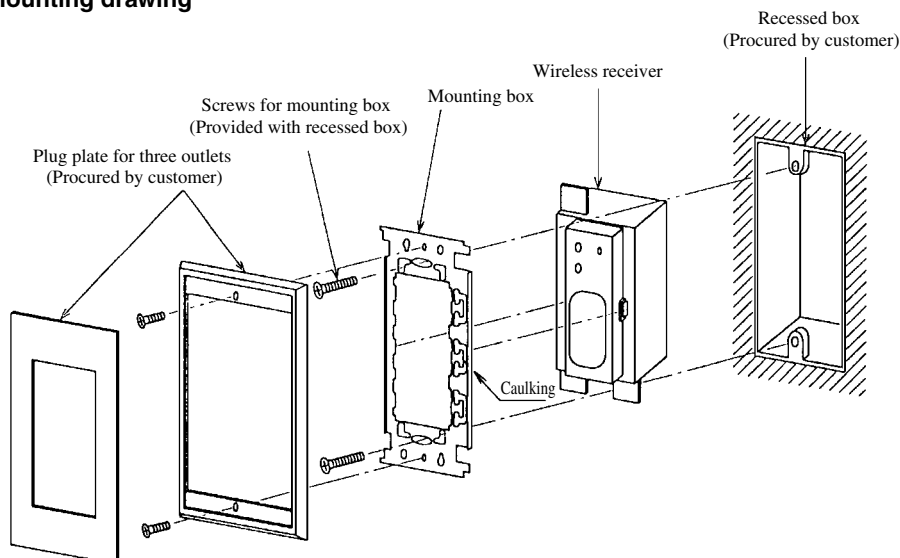

(2) Air outlet grille for suspended ceiling

(a) Part Number: RKB12

The air outlet grill for suspended ceiling is for mounting on the air outlet duct (RFD12) directly attached to the indoor unit.

(b) Parts list

Name	Qty.
Air outlet grille	1
Pan-head screws	4

(c) Installation

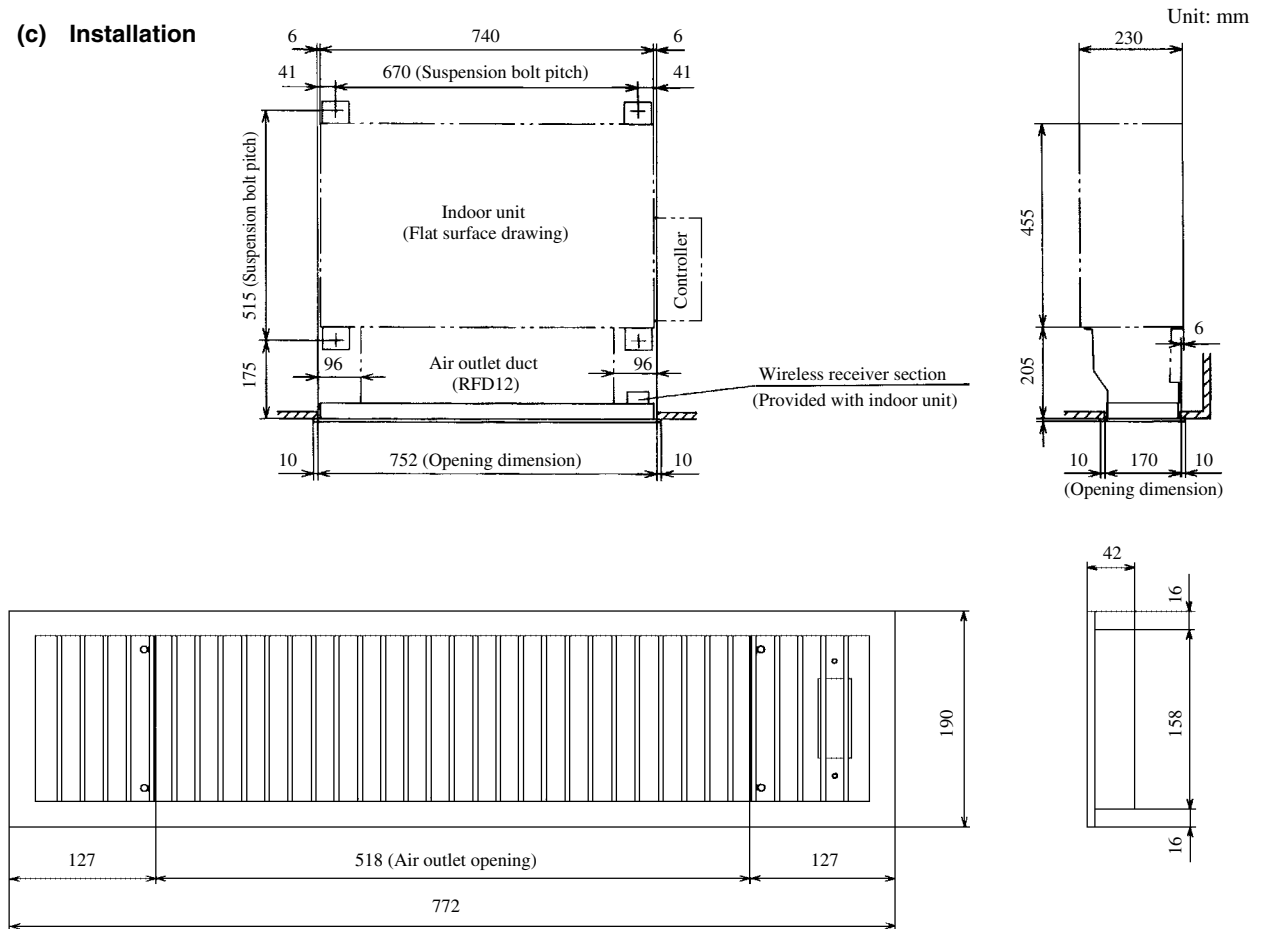

(d) Installation procedure

- 1) Mount the wireless receiver provided with indoor unit using the mounting hardware (provided with the indoor unit) so that it is on the right side of the air outlet grille and secure it with the countersunk screws (provided with the indoor unit).
- 2) Secure the air outlet grille with the pan-head screws.
- 3) Please refer to the wiring summary for the wireless receiver provided on the previous page.

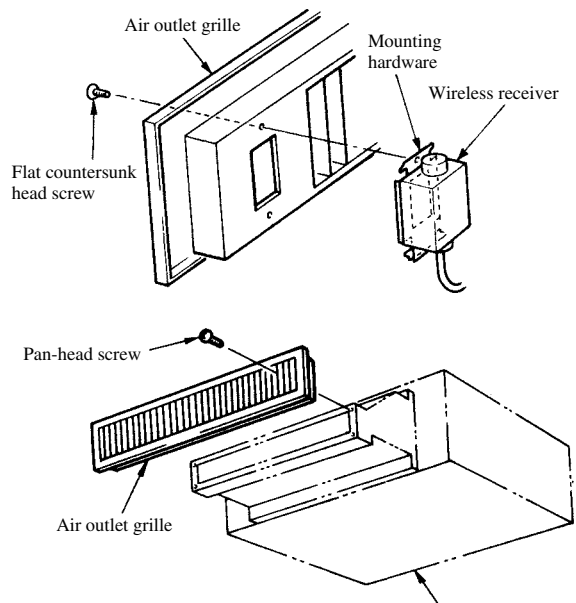

(3) Bottom air inlet grille set

(a) Part number: RTS12

(b) Parts list

Name	Qty.
Air inlet grille	1
Duct for air inlet grille	1
Tapping screw	10
Pan-head screws	4

(c) Installation

Unit: mm

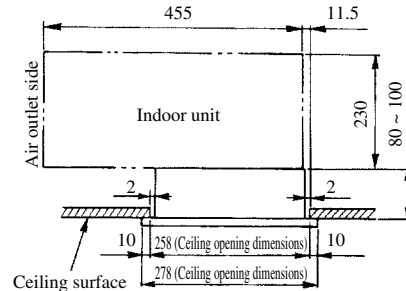
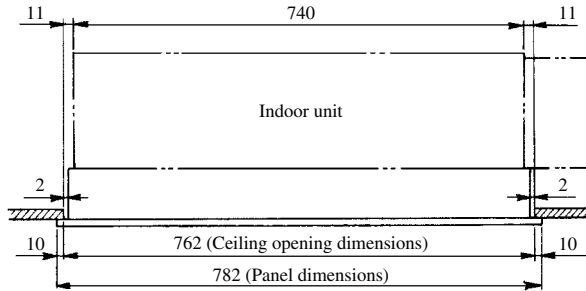

(d) Installation procedure

- 1) Mount the duct for the air inlet grille to the indoor unit using the 10 tapping screws provided. The tapping screws on the drain pan receiver side are also used for mounting the duct for the air inlet grille. They must first be removed and reinstalled after the duct for the air inlet grille is in place. A guideline for the height is to secure the assembly so that the lower surface of the duct for the intake grille is approximately 10 mm above the bottom surface of the ceiling.
- 2) Remove the center screw for the air inlet grille and open the grille as shown in the illustration. Next, insert the air inlet grille into the duct for the air inlet grille and secure it with the pan-head screws (the long screws).
- 3) Use the pan-head screws to make the small adjustments in height. The height dimension on the installation diagram allows for adjustment within range of 80 to 100 mm. If the pan-head screws are completely tightened, the height will be 80 mm.

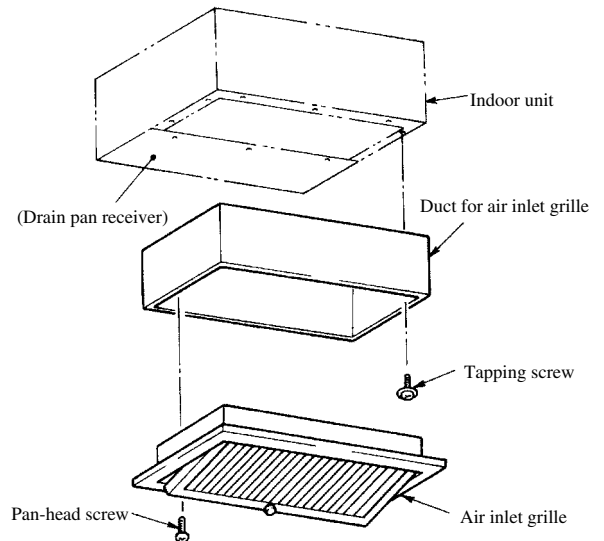

(4) Air outlet unit for ceiling

(a) Part number: RTB12

The air outlet unit uses a flexible duct (ø 150) for blowing the air. Keep the length of the flexible duct within 4 meters for each unit (straight line parts). (If there is a 90° bend, it should be 1.5 meters.)

(b) Parts list

Parts provide with air outlet unit for ceiling	
Name	Qty.
Air outlet chamber	1
Air outlet panel	1
Pan-head screw	4

Parts procured by customer	
Name	Qty.
Suspension bolts (M8)	2
Flat washers (M8)	4
Nuts (M8)	4

(c) Installation

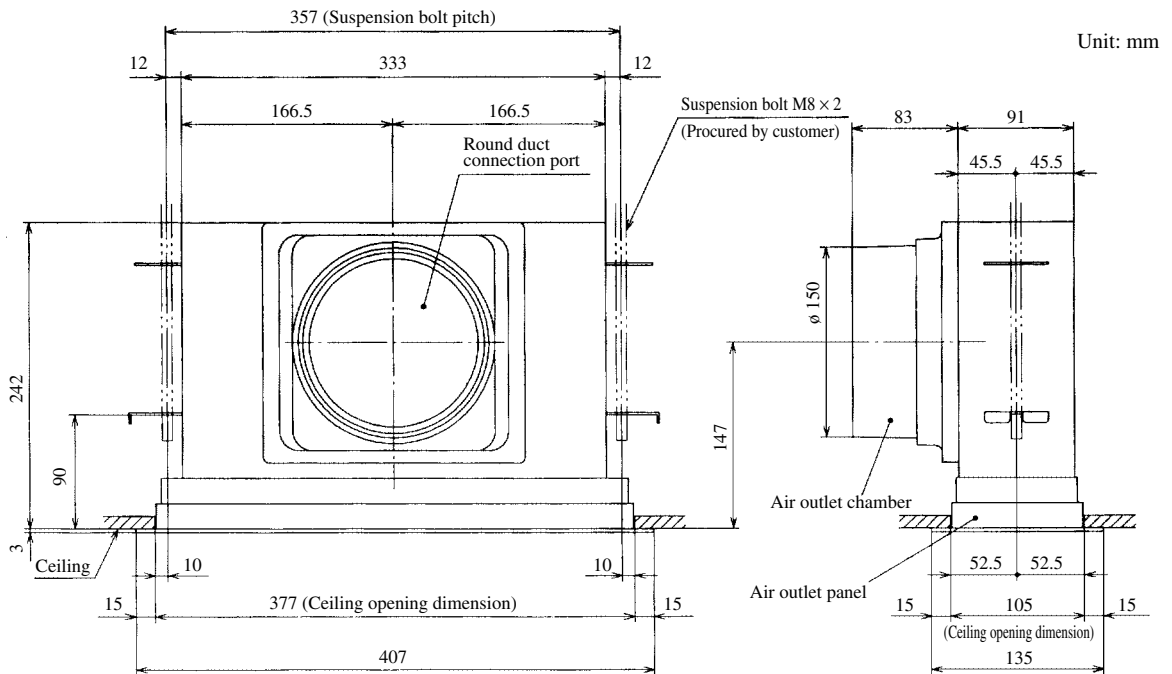

(d) Installation procedure

- 1) Use the bolts (M8 × 2) to secure the suspension hardware so that it is 90 mm below the ceiling surface.
- 2) Use the band to tightly secure the flexible duct (ø 150) to the air outlet chamber and duct joint on the indoor unit itself so that it will not come off and there will be escaping of air. Be sure to insulate this area from the top with heat insulation in order to prevent condensation.

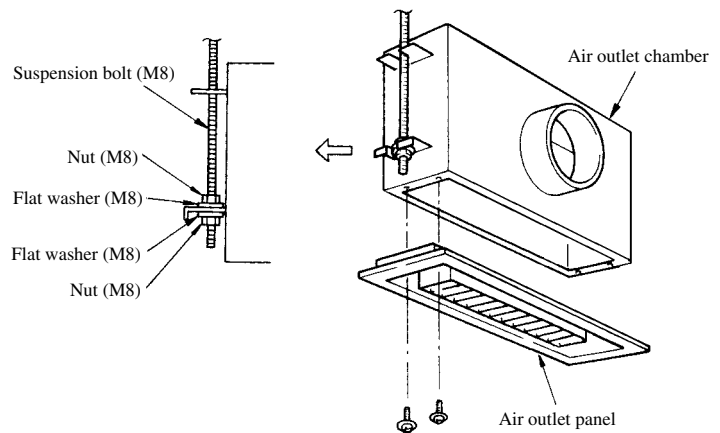

- 3) Use pan-head screws to secure the air outlet panel to the air outlet chamber. At this time, make sure there are no gaps between the air outlet chamber and the air outlet panel.

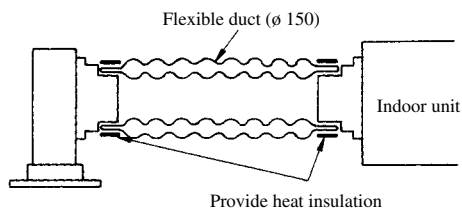

Note (1) If the outer covering of the flexible duct breaks, it can be repaired with tape or other such material. Escaping air could cause condensation.

(5) Flexible duct

Part number	Length (m)	Diameter (ø mm)	Parts provided
S97682	1	153 ⁺⁴ ₋₂	• Connecting bands (2) • Soft tape (2)
S97683	2		
S98223	3		
S97684	4		

(6) Duct joint for air outlet plate

(a) Part number: RFJ22

The duct joint is to be used when connecting the flexible duct (ø 150 mm) to the indoor unit.

(b) Part list

Name	Qty.
Duct joint	1
Tapping screws	8

(c) Installation

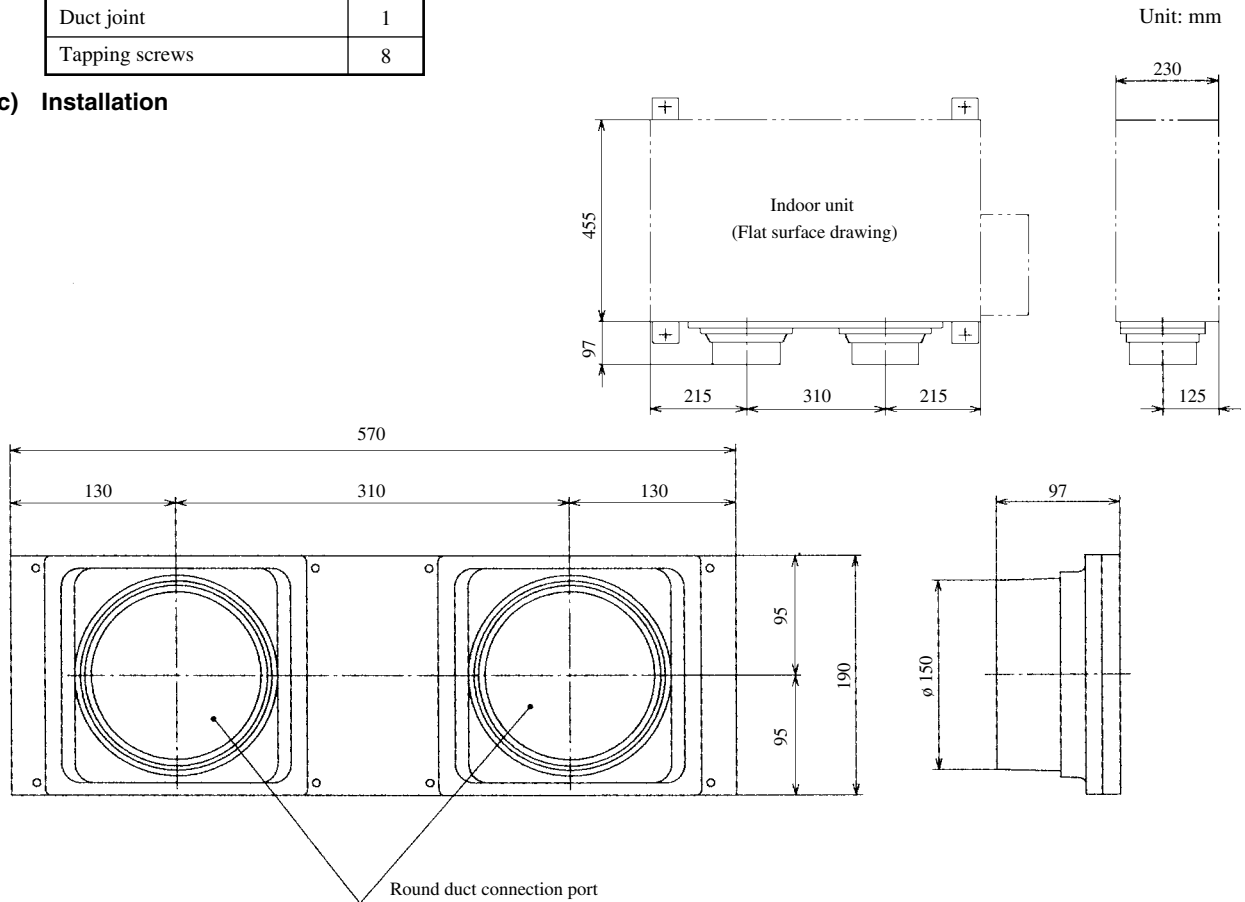

(d) Installation procedure

Use the tapping screws to mount the duct joint to the front of the indoor unit. Use care to prevent gaps from forming at the joining surfaces with the indoor unit. Use insulation at the connecting areas between the flexible duct and the duct joint to prevent condensation.

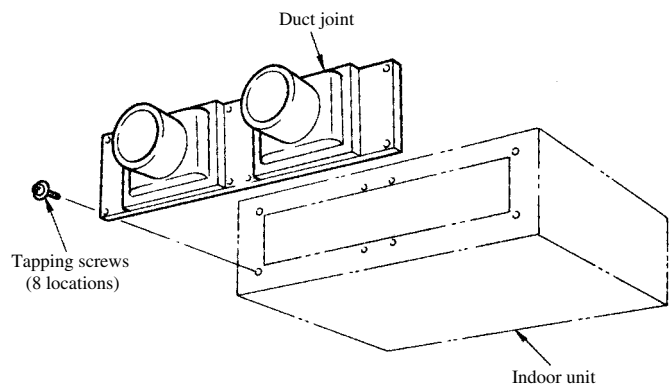

◆ **Air flow and external static pressure characteristics (Heating: Hi)**
SRRM40ZA

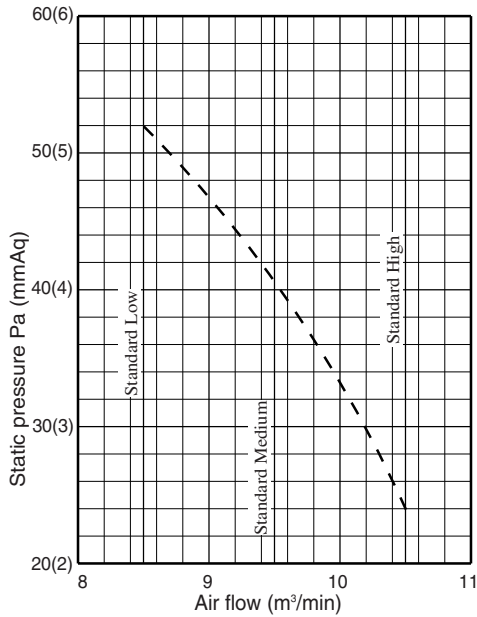

◆ **Air outlet unit air flow and friction loss characteristics**
 ● **Air outlet unit (Part number: RTB12)**
(Air outlet chamber + Air outlet panel)

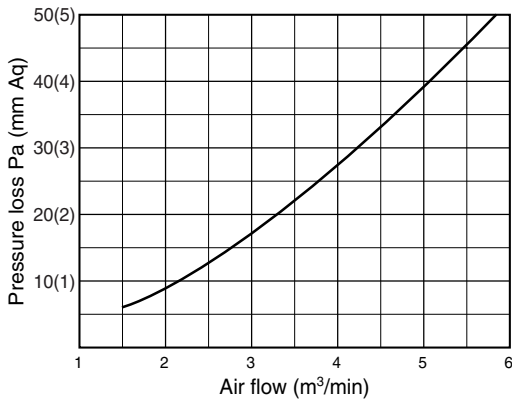

◆ **Air inlet grille air flow and friction loss characteristics**
(Part number: RTS12)

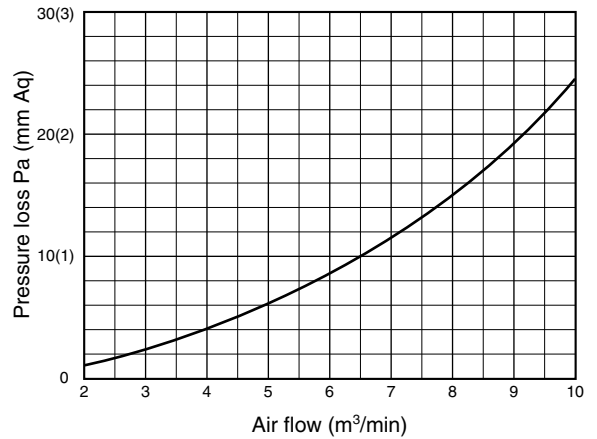

◆ **Flexible duct (ø 150) friction loss characteristics**

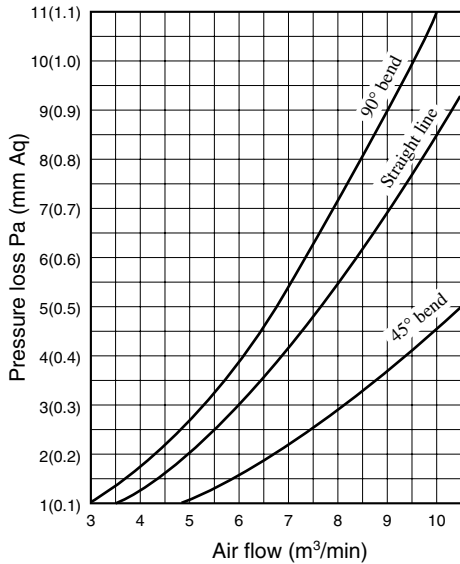

Pressure loss for:
 Straight line: per 1 meter
 90° bend: per 1 bend
 45° bend:

(7) Drain up kit

(a) Part No. : RDU12E

(b) Accessories

No.	Name	Qty.
①	Drain pump	1
②	Drain hose	1
③	Hose clamp	1
④	Tapping screw	4

(c) Installation of drain up kit

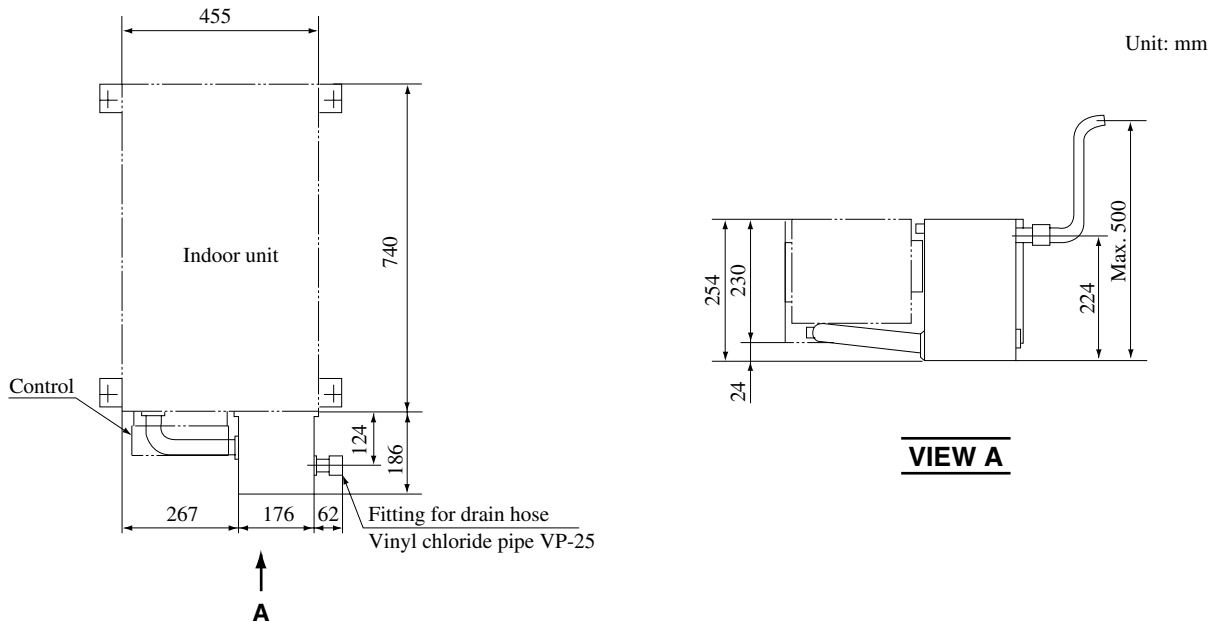

(d) Installation of drain up kit

- 1) Fix the drain up kit on the right side of the inside unit with tap screws.
- 2) Insert the drain hose fully and securely to the drain sockets of the inside unit and the drain up kit.
- 3) Connect the drain up kit's connectors for the drain pump (red color 2P) and the float switch (black 2P) to the connectors of the control box. (The control box's connectors for the drain pump and the float switch are also red and black respectively.) Note that the control's connector for the float switch is already connected to the inside unit's connector for the float switch, so disconnect them and connect it to the drain up kit's connector for the float switch and fix it with the wire clamp.

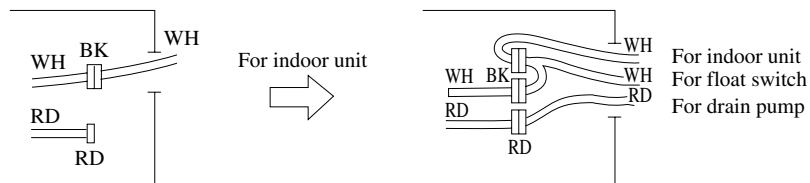
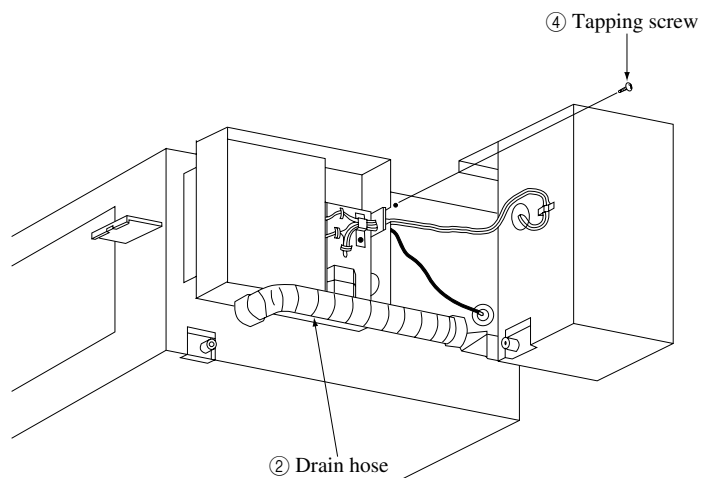

- 4) Use hard PVC general purpose pipes VP-25 sold on the market for drain pipes after draining up.
- 5) Tighten the PVC pipe securely with the attached clamp after inserting it in the drain socket.
- 6) The drain pipe must have downward inclination gradient of 1/100 or more, and take care not to make a trap or uphill pass.
- 7) When connecting the drain pipe, take care not to apply force on the pipe of the unit, and clamp the pipe as close as possible to the unit.
- 8) Don't attach air purge pipe, because the drain might spout.
- 9) Be sure to provide heat insulation to the indoor side drain pipe.

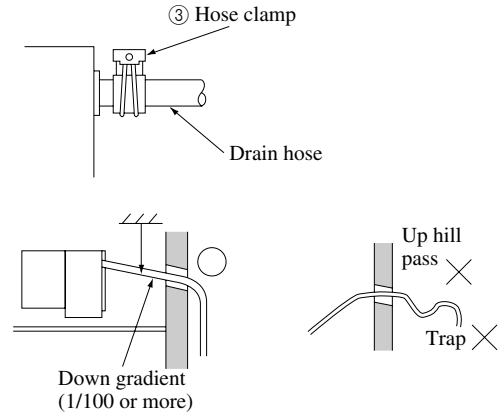

3.6 MAINTENANCE DATA

3.6.1 Trouble shooting

(1) Trouble shooting to be performed prior to exchanging PCB, (Printed circuit board)

All the models described in this chapter are controlled by a microcomputer. When providing maintenance service to customers it is necessary to understand the function controlled by a micro computer thoroughly, so as not to mistakenly identify correct operations as mis-operations. It is also necessary to perform the following simple checks before conducting detailed checks or exchanging printed circuit board.

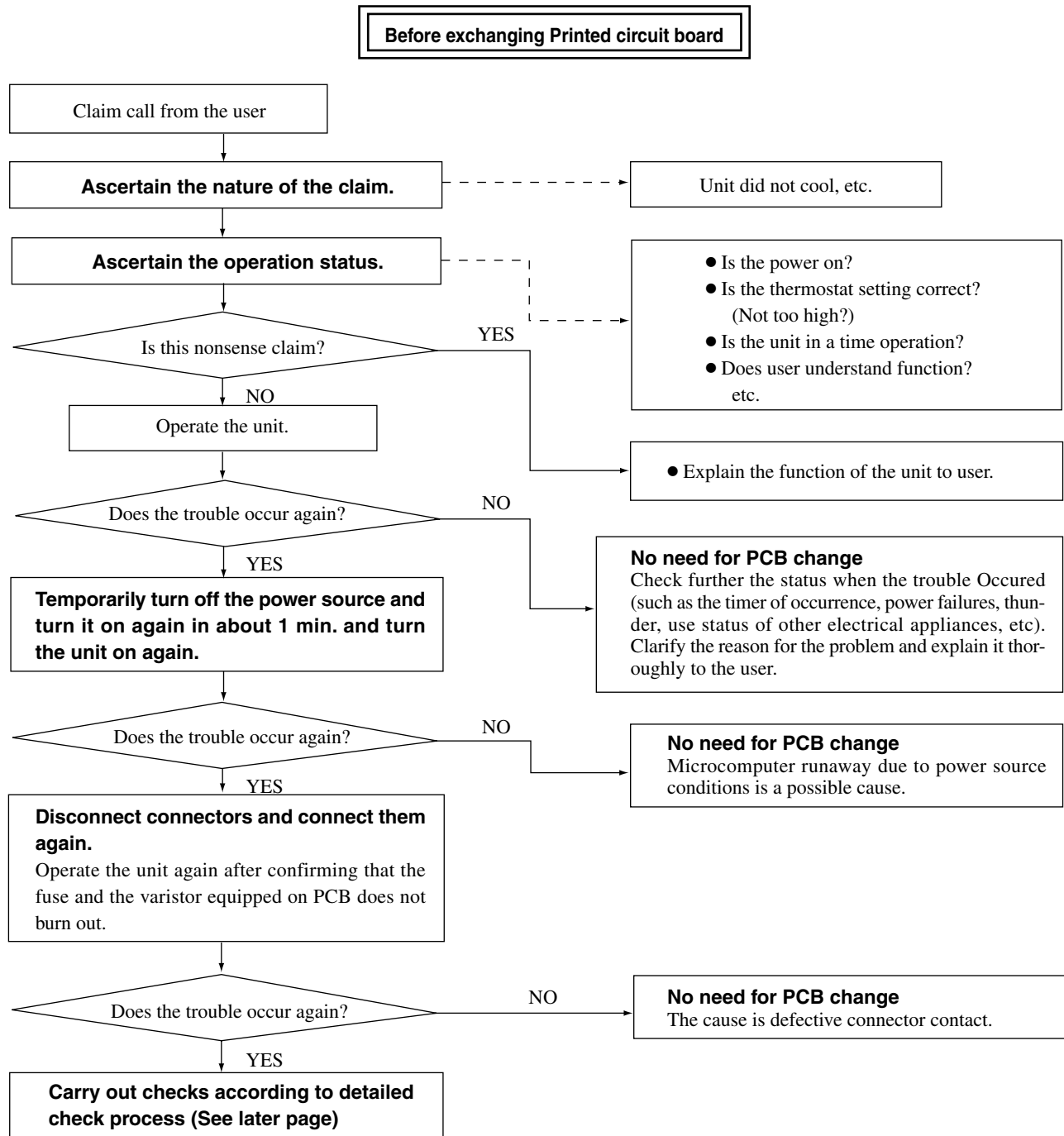

(2) Indication of self diagnosis

Indoor unit indicator		Outdoor unit indicator (LED5)	Description of trouble	Cause	Conditions of flashing
RUN lamp	TIMER lamp				
1 time flash	Comes on	Stays off	Indoor heat exchanger thermistor error	<ul style="list-style-type: none"> Broken heat exchanger thermistor wire Connector poor connection 	When heat exchanger thermistor temperature of -20°C or under continued for more than 3 seconds while operation is stopped. (This is not displayed during operation.)
2 time flash	Comes on	Stays off	Room temperature thermistor error	<ul style="list-style-type: none"> Broken room temperature thermistor wire Connector poor connection 	When room temperature thermistor temperature of -20°C or under continued for more than 3 seconds while operation is stopped. (This is not displayed during operation.)
5 time flash	Comes on	Stays off	Drain abnormality ⁽¹⁾	<ul style="list-style-type: none"> Drain at reverse gradient Float switch defective 	Float switch motion
6 time flash	Comes on	Stays off	Indoor fan motor error ⁽²⁾	<ul style="list-style-type: none"> Defective fan motor Connector poor connection 	When air conditioner is operating and indoor fan motor is turned ON, indoor fan motor speed of 400 rpm or under continued for more than 30 seconds. (Air conditioner stops.)
Keeps flashing	1 time flash	Stays off	Outdoor temperature thermistor error	<ul style="list-style-type: none"> Broken outdoor thermistor wire Poor connector connection 	When outdoor temperature sensor temperature of -40°C or under continued for more than 3 seconds while operation is stopped. (This is not displayed during operation.)
Keeps flashing	2 time flash	Stays off	Outdoor heat exchanger gas pipe thermistor error	<ul style="list-style-type: none"> Broken heat exchanger gas pipe thermistor wire Poor connector connection 	When heat exchanger entrance thermistor temperature of -50°C or under continued for more than 3 seconds while operation is stopped. (This is not displayed during operation.)
Comes on	1 time flash	1 time flash	Current cut	<ul style="list-style-type: none"> Compressor locking Open phase on compressor output Shortcircuit on power transformer 	When converter output current which exceeds setting value is detected. (Compressor stops.)
Comes on	2 time flash	2 time flash	Trouble of outdoor unit	<ul style="list-style-type: none"> Broken power transformer Broken compressor wire Compressor blockage 	When the input current of 1 A or less is detected for 30 continuous seconds or more. (Compressor stops.)
Comes on	2 time flash	On for 4 seconds and off for 4 seconds	Discharge pipe thermistor error	<ul style="list-style-type: none"> Broken discharge pipe thermistor wire Connector poor connection 	When the discharge pipe thermistor temperature measures an interrupted signal (less than 7°C) of 10 seconds or more.
Comes on	3 time flash	3 time flash	Over current	<ul style="list-style-type: none"> Overload operation Overcharge 	When the input current value exceeds the set value. (Compressor stops)
Comes on	4 time flash	4 time flash	Over heat of power transistor	<ul style="list-style-type: none"> Cooling problem 	When power transistor temperature exceeds setting value. (Compressor Stops.)
Comes on	5 time flash	5 time flash	Over heat of compressor	<ul style="list-style-type: none"> Gas shortage Defective discharge pipe thermistor 	When discharge pipe thermistor value exceeds setting value. (Compressor Stops.)
Comes on	6 time flash	6 time flash ⁽³⁾	Error of signal transmission	<ul style="list-style-type: none"> Defective power supply Broken signal wire Defective indoor/outdoor unit circuit boards 	If serial signal cannot be sent or received for 1 minute and 55 seconds continuously.

Notes (1) Ceiling recessed type only

(2) Wall mounted type only

(3) LED 5 will go out when even one unit is operating properly or there is an abnormality with the outdoor unit power supply. It will also go out during normal operation.

(3) Inspection procedures corresponding to detail of trouble

Thermistor error

[Broken thermistor wire, connector poor connection]

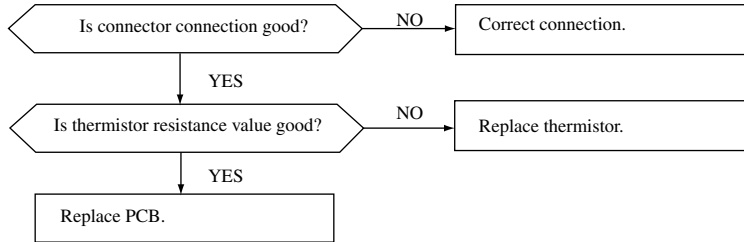

◆ Discharge pipe thermistor temperature characteristics

Temperature (°C)	Resistance (kΩ)	Temperature (°C)	Resistance (kΩ)
0	164	70	8.7
5	127	75	7.3
10	99	80	6.2
15	78	85	5.3
20	62	90	4.5
25	50	95	3.9
30	40	100	3.3
35	32	105	2.9
40	26	110	2.5
45	21	115	2.2
50	17	120	1.9
55	14	125	1.6
60	12	130	1.4
65	10	135	1.3

◆ Thermistor temperature characteristics (Room temp., indoor and outdoor unit heat exchanger temp., outdoor temp.)

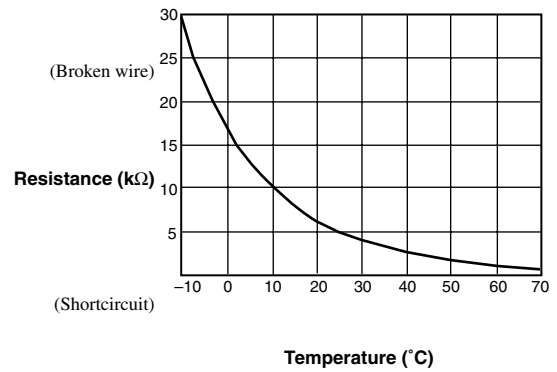

Current cut

[Open phase on compressor output terminal, compressor lock]

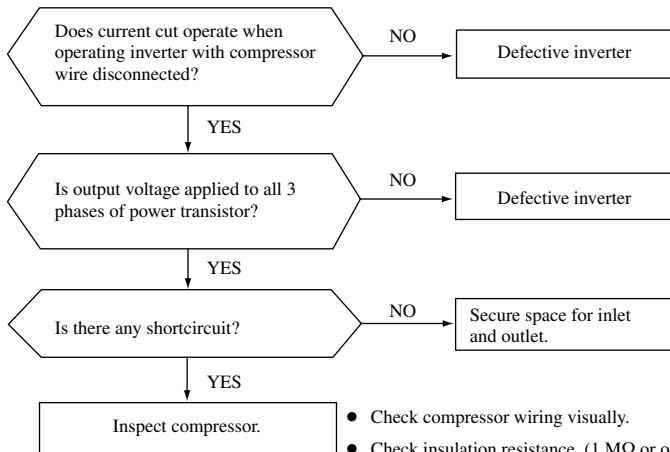

- Check compressor wiring visually.
- Check insulation resistance. (1 MΩ or over)
- Check coil wire resistance. (Few Ω)

If check results are normal, compressor is locked.

Outdoor unit error

[Broken power transistor, broken compressor wire]

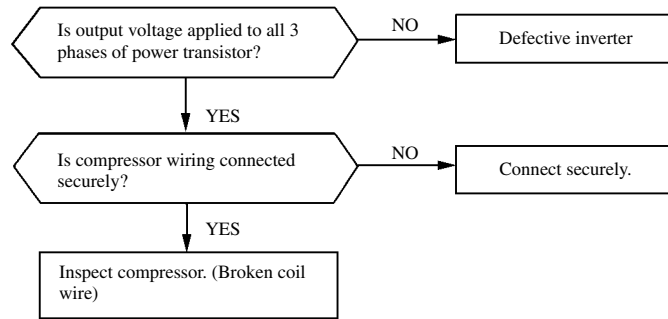

Over current

[Overload operation, compressor lock, overcharge]

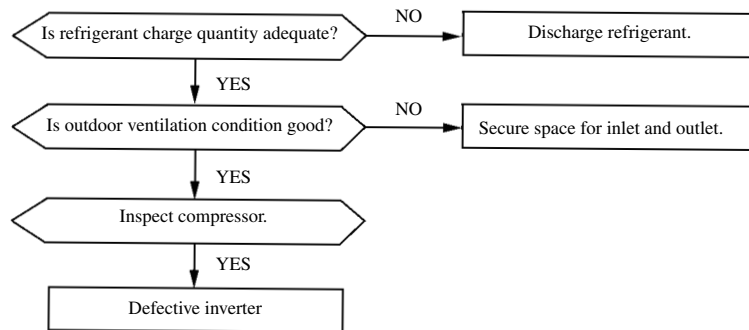

Power transistor overheating

[Poor cooling]

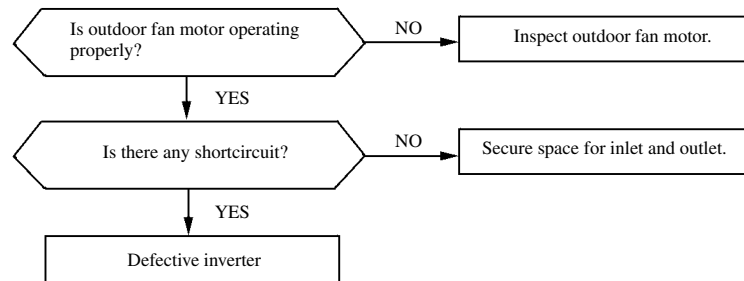

Compressor overheating

[Gas shortage, defective discharge pipe thermistor]

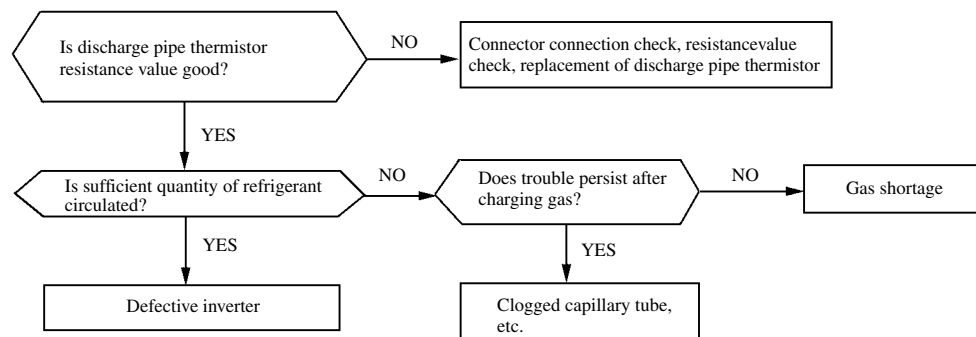

Serial signal transmission abnormality

[Indoor/outdoor printed circuit board defect
Outdoor power source abnormality]

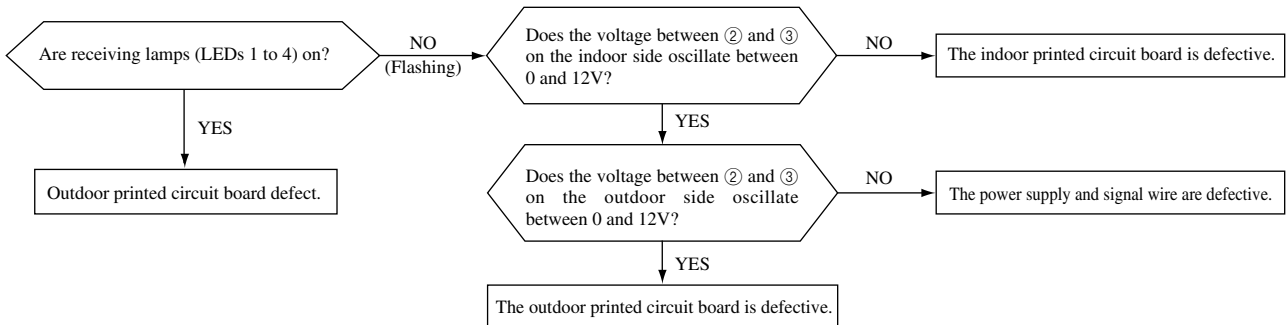

Indoor fan motor error

[Defective fan motor,
defective PCB]

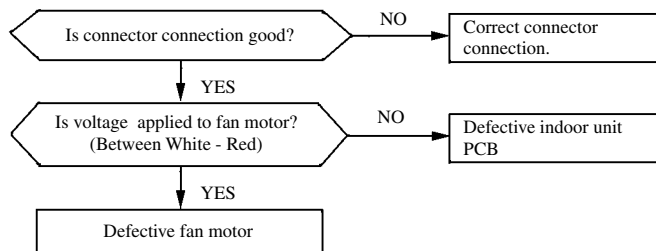

Drain abnormality

[Drain piping defective,
pump defect]

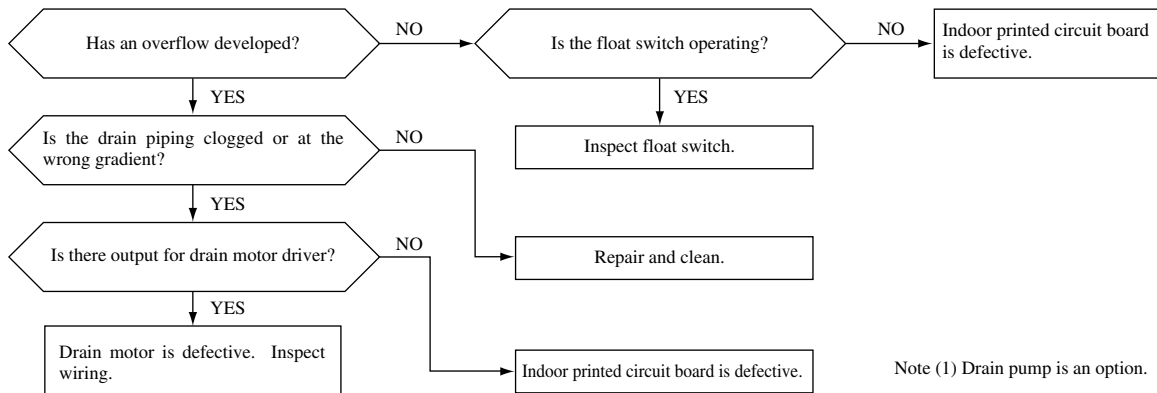

Note (1) Drain pump is an option.

(4) Phenomenon observed after shortcircuit, wire breakage on thermistors, etc.

(a) Indoor unit

Thermistor	Operation mode	Phenomenon	
		Shortcircuit	Broken wire
Room temperature thermistor	Cooling	Release of continuous compressor operation command	Continuous compressor operation command is not released.
	Heating	Continuous compressor operation command is not released.	Release of continuous compressor operation command
Heat exchanger thermistor	Cooling	System can be operated normally.	Continuous compressor operation command is not released. (Anti-frosting)
	Heating	High pressure control mode (Inverter stop command)	Hot keep (Indoor fan stop)

(b) Outdoor unit

Thermistor	Operation mode	Phenomenon	
		Shortcircuit	Broken wire
Heat exchanger pipe thermistor	Cooling	System can be operated normally.	
	Heating	Defrosting is not performed.	Defrosting is performed for 10 minutes at approx. 30 minutes.
Outdoor temperature thermistor	Cooling	System can be operated normally.	
	Heating	Defrosting is not operated.	Defrosting is performed for 10 minutes at intervals of approx. 30 minutes.
Discharge pipe thermistor	All modes	Compressor overload protection is disabled. (Can be operated.)	Compressor stop (There is no inverter output.)

(5) How to make sure of remote controller

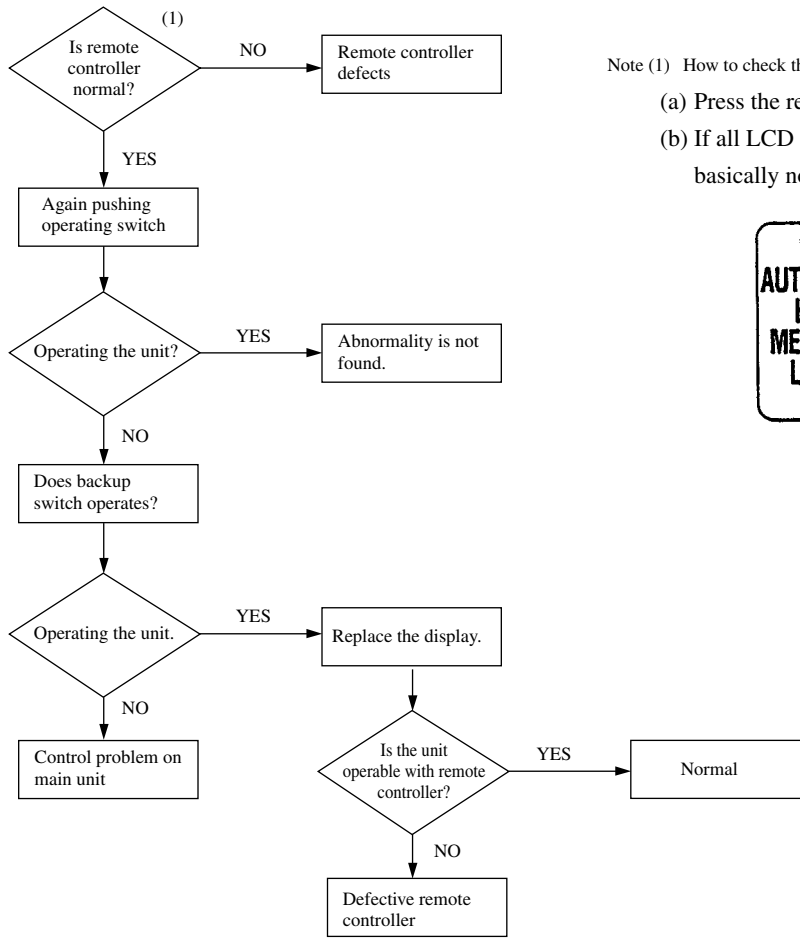

Note (1) How to check the remote controller

- (a) Press the reset switch of the remote controller.
- (b) If all LCD are displayed after zero (0) display, it is basically normal.

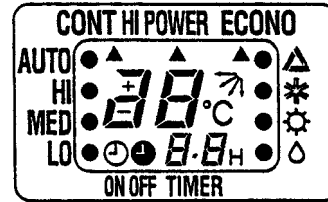

(6) Indoor electrical components inspection flow-chart

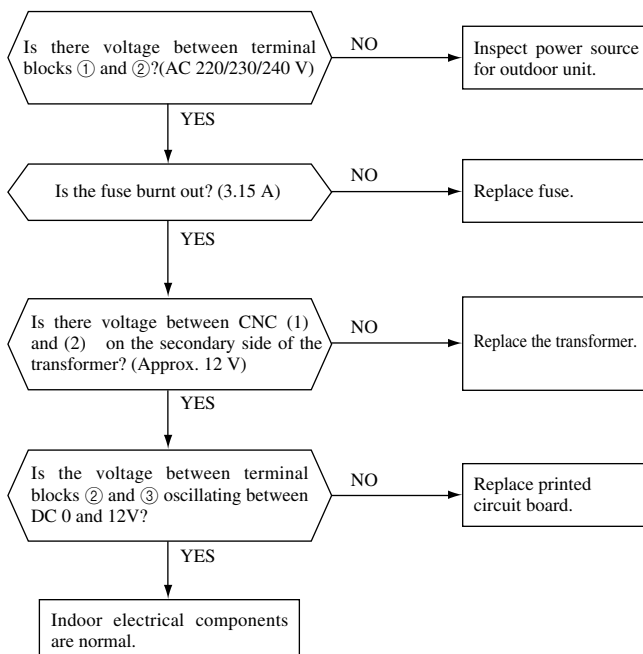

Note (1) Excepted 50 model

(7) Inverter failure diagnosis

If the results of the diagnosis in Item (3) indicate that the inverter is defective, perform the following inspection on the inverter.

(a) Diagnosis procedure

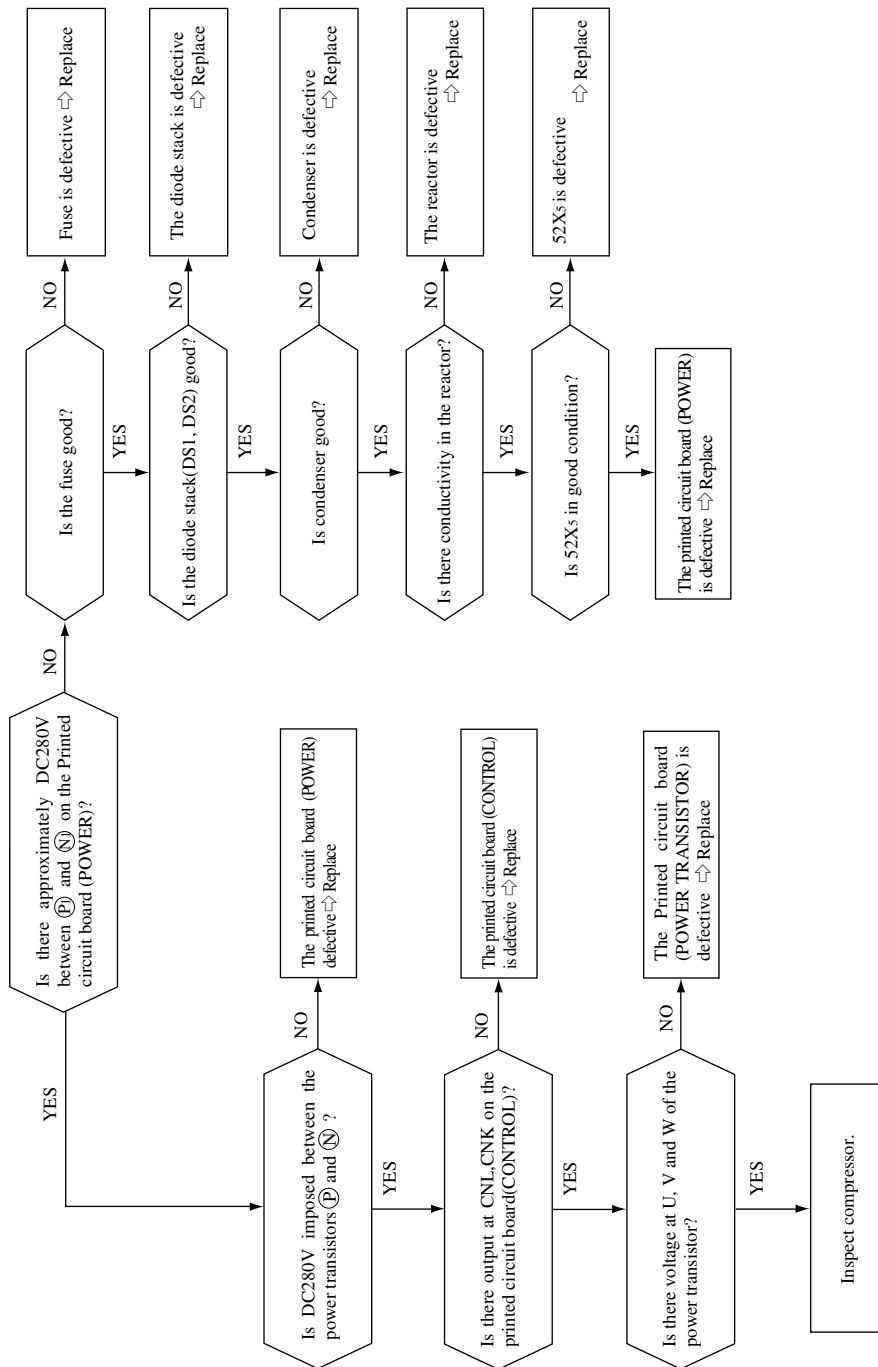

(b) Outdoor unit inspection points

CAUTION – HIGH VOLTAGE
 High voltage is produced in the control box. Don't touch electrical parts in the control box for 5 minutes after the unit is stopped.

▷ ⊗ Check these points with the power supply on.

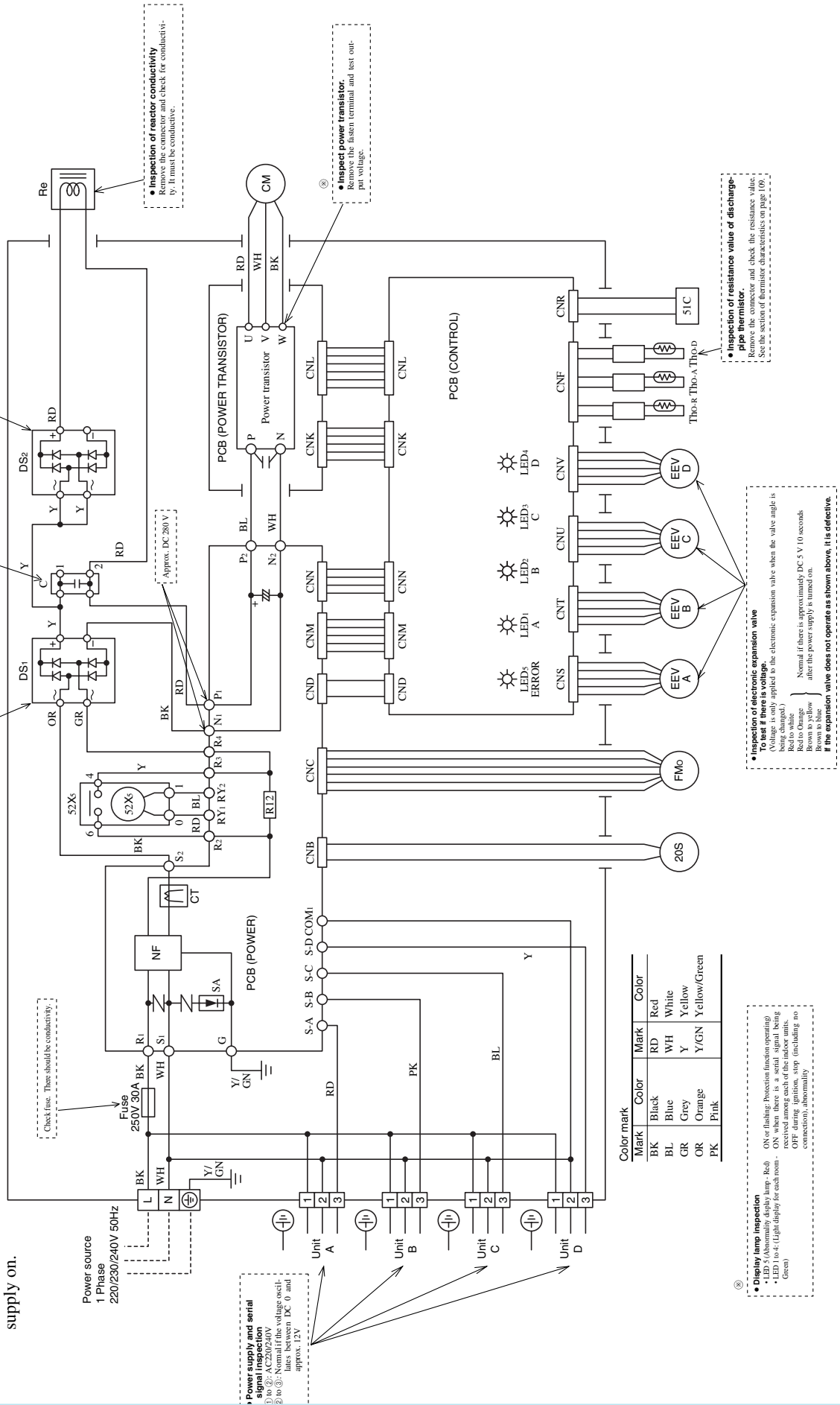

• Inspection of diode stack (DS1)

Tester probe	Normal condition
⊕	⊖
+ (RD) + (GR)	∞
+ (RD) + (BK)	∞
- (GR) - (BK)	∞
- (GR) - (RD)	∞

• Inspection of diode stack (DS2)

Tester probe	Normal condition
⊕	⊖
+ (BL) - (RD)	∞
+ (BL) - (BK)	∞

• Inspection of capacitor
 Check the charging characteristics with a tester. (Needle should swing and return slowly. Change the polarity of the needle. If the needle returns, it is normal.)

• Inspection of reactor conductivity
 Remove the connector and check for conductivity. If it cannot be conducted.

• Inspection of power transistor.
 Remove the fasten terminal and test output.

• Inspection of resistance value or discharge pipe thermometer.
 Remove the connector and check the resistance value. Scores differ according to the characteristics (page 109).

• Inspection of electronic expansion valve
 Voltage is only applied to the electronic expansion valve when the valve angle is being changed.)
 Normal: Red to white, Red to orange, Red to blue, Brown to blue.
 If the expansion valve does not operate as shown above, it is defective.

Color mark

Mark	Color	Mark	Color
BK	Black	RD	Red
BL	Blue	WH	White
GR	Grey	Y	Yellow
OR	Orange	Y/GN	Yellow/Green
PK	Pink		

• Display lamp inspection
 • LED 5 (Abnormally display lamp - Red)
 • LED 1 (ok - Light display for each room)
 • LED 1 (ok - Light display for each room)
 ON or flashing: Protection function operating)
 ON when there is a fault signal being sent
 OFF during ignition, stop (including no connection), abnormally

• Power supply and serial signal inspection
 ① to ②: AC220/240V voltage oscil.
 ② to ③: DC voltage oscil. approx. 12V

3.6.2 Servicing

(1) Evacuation

The evacuation is a procedure to purge impurities.....noncondensable gas, air, moisture from the refrigerant equipment by using a vacuum pump. Since the refrigerant R22 is very insoluble in water, even a small amount of moisture left in the refrigerant equipment will freeze, causing what is called water clogging.

- Evacuation procedure (a) Check to ensure that there is no internal pressure in the unit. If there is an internal pressure, it should be relieved through the check joint.
- (b) Connect the service hoses of the gauge manifold to the check joint of the gas & liquid piping.
- (c) Connect a vacuum pump to the charge hose A. Repeat evacuation in the following sequence.

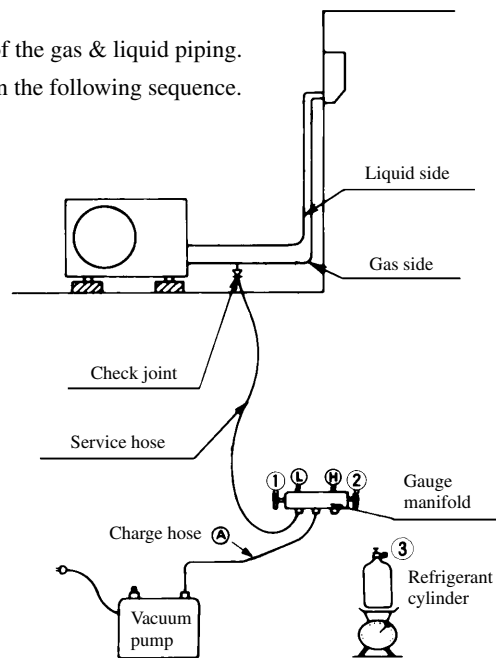
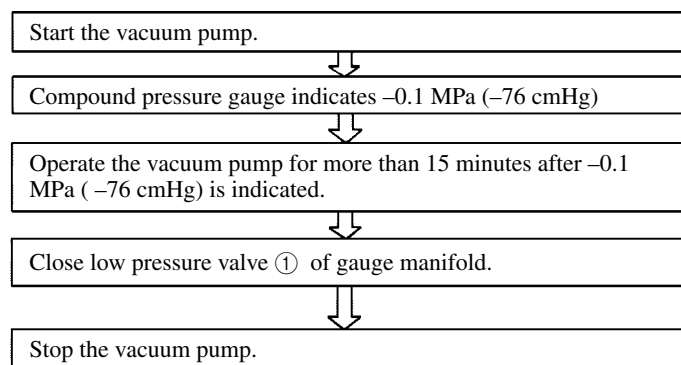

- Notes
- (1) Do not use the refrigerant pressure to expel air.
 - (2) Do not use the compressor for evacuation.
 - (3) Do not operate the compressor in the vacuum condition.

(2) Refrigerant charge

- (a) Discharge refrigerant entirely from the unit and evacuate the unit.
Note: Addition of refrigerant without evacuation is unreasonable, because it will result in low charge or overcharge.
- (b) Keep the gauge manifold and connect a refrigerant cylinder to the unit.
- (c) Record the weight of the refrigerant cylinder on the balance. This is necessary for making sure of the charged refrigerant amount.
- (d) Purge air from the charge hose (A)
Firstly loose the connecting portion of the charge hose (A) at the gauge manifold side and open the valve (3) for a few seconds, and then immediately retighten it after observing that gas is blow out from the loosened portion.
- (e) Open the valve (1) and (3) after discharging air from the charge hose (A), then the gas refrigerant begins flowing from the cylinder into the unit. Be sure to erect the refrigerant cylinder upright to let gas refrigerant flow into the unit.
- (f) When refrigerant has been charged into the system to some extent, refrigerant flow becomes stagnant, when that happens, start the compressor in cooling cycle until the unit is filled with gas to the specified weight.
- (g) Making sure of the refrigerant amount, close the valve (3) (h)
Disconnect the charge hose from the unit. Cover the valve ports of the refrigerant piping with caps and tighten them securely.
- (i) Check for gas leakage applying a gas leak detector along the piping line.
- (j) Start the air conditioner and make sure of its operating condition.high side and low side pressures and temperature difference between suction air and outlet air.



Большая библиотека технической документации

<https://splitsystema48.ru/instrukcii-po-ekspluatacii-kondicionerov.html>

каталоги, инструкции, сервисные мануалы, схемы.